

## 600-Series Aluminum Overhung-mount Pedal Assembly

### DESCRIPTION

The Tilton Overhung-mount pedal assembly has been designed to provide the driver with the greatest control and comfort from a swing-style pedal assembly. The adjustable (5.0:1 to 6.2:1) pedal ratio delivers the optimum pedal profile.

Forged aluminum pedals provide the strength and durability to handle the most severe braking conditions. The pedal assembly is set up for dual brake master cylinders and includes the balance bar assembly. The balance bar allows adjustment of the brake pedal force distribution between the two master cylinders. This system can be used to compensate for fuel load changes, tire wear, and changing track conditions.

The Remote Brake Bias Adjuster is also available as an option. This connects to the balance bar and allows the driver to make balance bar adjustments quickly while on track.

Fluid reservoirs can be directly mounted to the master cylinders or can be remotely mounted based on your application. It is important to follow these setup instructions closely to realize the benefits of this design.

### INSTALLATION NOTES

- Securing the pedal frame to a cross-member will greatly enhance the stability of the pedal assembly.
- The mounting location should suit the driver and also provide a stable platform.
- Be sure that there is no binding during the full stroke of the master cylinders when the pedal is depressed.
- The balance bar mechanism must clear all obstructions when the balance bar is adjusted to the extreme right or left-of-center.
- If you have decided to remotely mount the reservoirs, select the location for the reservoirs before starting installation.
- This is a gravity fed system, so the reservoirs must be located above the master cylinders.
- Attention must be paid to the routing and location of the hydraulic lines. Avoid heat sources such as exhaust pipes.
- Accurate clutch pedal setup is critically important. Improper clutch pedal installation and/or adjustment can result in expensive clutch damage and DNFs at the track!

### INSTALLATION

1. Set the clevis center-to-center distance at 2.620 +/- .050" (see **Diagram 5**). You need to do this before attaching the master cylinders.
2. Thread the balance bar left or right until the spherical bearing is near the center of the pivot sleeve. Note that the right end of the balance bar has a longer threaded section and will stick out further.
3. If you are using a remote adjuster, remove the jam-nut from the balance bar shaft. If you are not using a remote adjuster, tighten the jam-nut against the barrel nut on the longer end (right end) of the shaft. The round end goes against the barrel nut.
4. Mount the pedal assembly in the car. It is important to mount the frame rigidly so that it does not move when heavy pedal force is applied to both pedals. The four large through holes are for attaching to the main support structure while the two tapped holes and the six master cylinder mounting studs can be used for additional stiffening.
5. If you are going to bench bleed your master cylinders, now is the time.



Master cylinders sold separately

**Diagram 1**

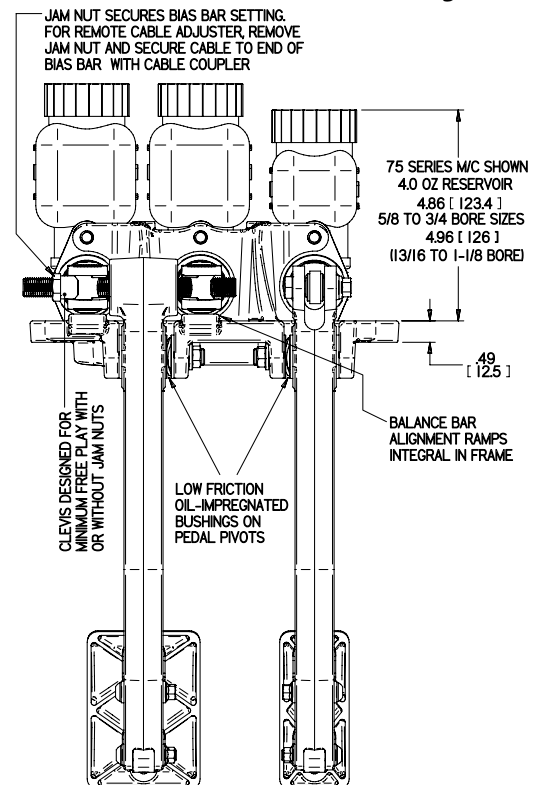

## BRAKE PEDAL SETUP

1. Bolt the master cylinders into place with the supplied 5/16"-24 serrated flange nuts. Make sure each master cylinder pushrod has a jam-nut.
2. Thread the master cylinder pushrods into the clevises equal amounts (you may need to alter this later) until the pedal foot pad is in the correct position for the driver (See **Diagram 2**). A minimum of .25" thread engagement (6 threads) is recommended.
3. Make sure that the chosen pedal position allows a full 1" of stroke at both master cylinders.
4. Make sure that the adjusted position also allows both master cylinders to return to their fully relaxed position without binding. Preload on the master cylinder pushrods can cause the brakes to lock up when hot when there is no force on the pedal.
5. Install the intermediate pad adapter onto the end of the pedal in the desired position/ratio. Use two non-adjacent holes in the pedal (see **Diagram 2**) and two high-strength bolts with washers and lock-nuts (supplied). Torque nuts to **70 in-lbs dry**. Attach pedal pad in desired location with two button-head screws (supplied). See the installation drawings for further details.
6. Attach hydraulic lines.
7. Attach the reservoirs and bleed as directed in the master cylinder instructions. With a balance bar, always bleed a front and a rear caliper at the same time to ensure total air removal.
8. Apply the brakes and adjust the pushrod length so the balance bar is parallel to the master cylinder mounting surface (See **Diagram 4**). If one pushrod is shortened by one revolution, lengthening the other by one revolution will maintain the same pedal position. Do not extend the pushrods to the point where they preload the master cylinder pistons.
9. After adjusting, tighten the jam-nuts on both pushrods (**144 in-lbs**).
10. You will need to test drive the vehicle to determine if adjustments need to be made to the brake bias (front/rear brake force distribution).

## CLUTCH PEDAL SETUP

1. Install the clutch master cylinder using the supplied 5/16"-24 serrated flange nuts. Make sure that there is a jam-nut on the pushrod.
2. Thread the pushrod into the rod end on the clutch pedal until the pedal is in the desired position, which is usually a matter of driver preference. A minimum of .25" thread engagement (6 threads) is recommended. You may need to shorten the pushrod for some positions.
3. Tighten the jam-nut against the spherical rod end. (**144 in-lbs**).
4. Connect the hydraulic line to the master cylinder.
5. Fill the master cylinder reservoir with brake fluid. Do not use a silicone-based fluid.
6. Open the bleed fitting at the master cylinder, or loosen the line.
7. Gently depress and release the clutch pedal until fluid emerges.
8. Tighten the bleed fitting or line.
9. Fill the reservoir with brake fluid.
10. Place a light force on the pedal. You want enough to hold the bearing out against the clutch diaphragm spring but not enough to compress it.

**Diagram 2**

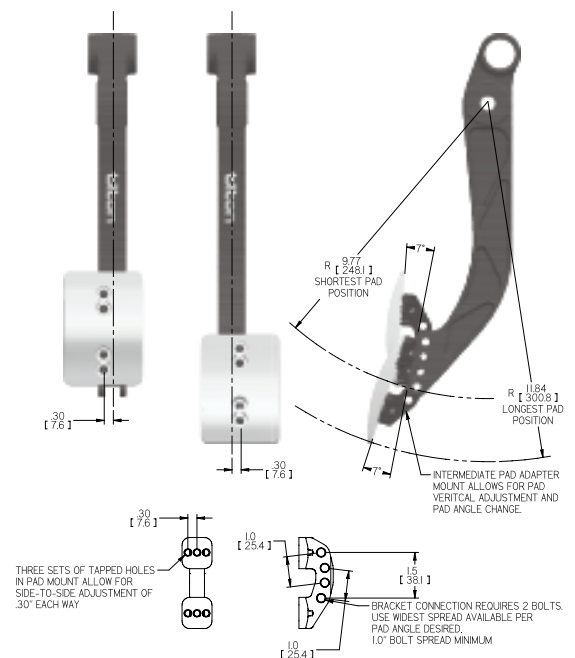

**Diagram 3**

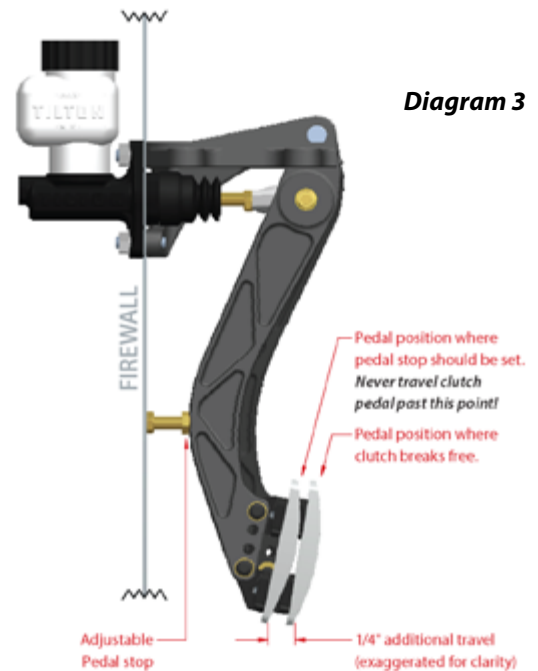

**Diagram 4**

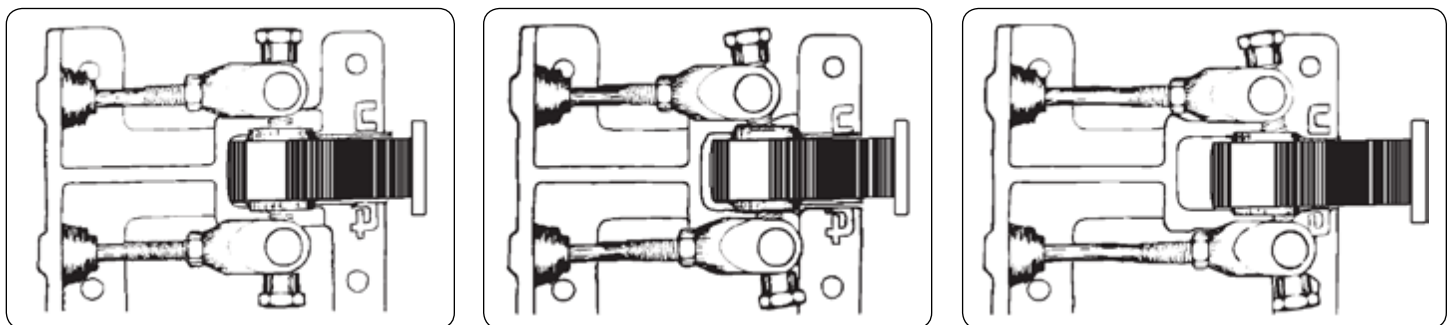

**3.1** Pedal Depressed

*Balance Bar not at an angle* (Correct)

**3.2** Pedal Depressed

*Balance Bar at an angle* (Incorrect)

**3.3** Pedal Relaxed

*Balance Bar may or may not be at an angle*

11. Open the bleed screw for the hydraulic release bearing.
12. Completely stroke the pedal.
13. Close the bleed screw.
14. Let the pedal return to its natural position and wait 4 seconds.
15. Repeat steps 10-14 until all air is removed from the system.
16. Proceed directly to setting the pedal stop before stroking the pedal again or the clutch could be damaged. A pedal stop is usually required for small diameter racing clutches and/or hydraulic release bearings with limited stroke.

## CLUTCH PEDAL STOP SETUP

### (For use with Tilton style hydraulic release bearings)

1. Raise the vehicle onto jack stands or a hydraulic lift.
2. With the engine off, put the transmission into 1<sup>st</sup> gear (without depressing the clutch pedal) and have someone attempt to rotate one of the drive wheels.
3. Depress the clutch pedal slowly until the clutch disengages and the drive wheel can be rotated (see **Diagram 3**).
4. Note the clutch pedal position at this point.
5. Adjust the pedal stop bolt to allow an additional 1/4" of pedal travel at the foot.

## MAINTENANCE

Periodic inspections of the brake and clutch pedal assemblies should be conducted routinely. Pay particular attention to the balance bar and pivot areas.

## BALANCE BAR ADJUSTMENT AND OPERATION

When running on pavement, you want the front tires to lock-up with slightly less pedal pressure than the rear tires. This will help to keep the car stable and prevent it from going into a spin. When an (item) is mentioned, please refer to **Diagram 6**.

1. Loosen the jam-nut (item 3) on the balance bar (item 8).  
A jam-nut is not used with a remote adjuster.
2. Turn the balance bar (item 8) by hand or with the remote cable adjuster so that it advances the spherical bearing closer to the selected master cylinder, increasing the braking force produced by that master cylinder (see **Chart 1**).  
The balance bar must be adjusted with the pedal in the relaxed position. It will not rotate while depressing the pedal.
3. The balance bar has a fairly large adjustment range. However, if you find that what you need is outside of the adjustment range, you will need to make a master cylinder bore size change. There are three possible changes that can be made (See a, b, and c below). All three will allow the spherical bearing to move back towards the center position.
  - a) Decrease the bore size of the master cylinder closest to the spherical joint by 1/8". This will decrease the amount of pedal force required from the foot and increase the amount of pedal travel.
  - b) Increase the bore size of the master cylinder farthest from the spherical bearing by 1/8". This will increase the amount of pedal force required by the foot and decrease the amount of pedal travel.
  - c) Increase the bore size of the master cylinder farthest from the spherical joint by 1/16". Decrease the other master cylinder bore size by 1/16". This will maintain the amount of force and pedal travel while making a relatively large change to the front/rear brake bias.
4. Whenever making an adjustment, remember to tighten the jam-nut (item 3) afterwards. A jam-nut is not required when a Remote Brake Bias Adjuster is used.

**Diagram 5**

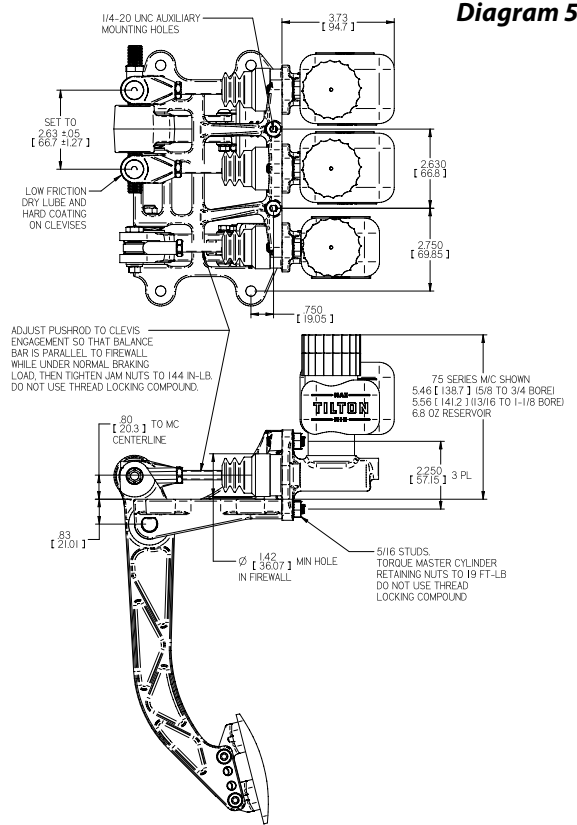

**Chart 1**

Force Distribution (2.62" Clevis Center-to-Center)		
Spherical Joint Position	Left Clevis	Right Clevis
3/8" left-of-center	64.3%	35.7%
1/4" left-of-center	59.5%	40.5%
1/8" left-of-center	54.8%	45.2%
Centered	50.0%	50.0%
1/8" right-of-center	45.2%	54.8%
1/4" right-of-center	40.5%	59.5%
3/8" right-of-center	35.7%	64.3%

**Diagram 6**

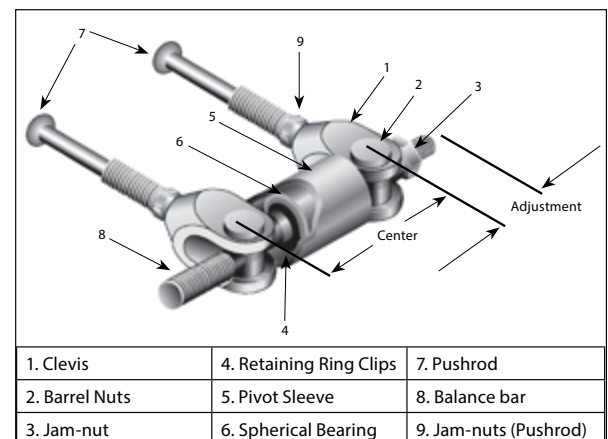

1. Clevis	4. Retaining Ring Clips	7. Pushrod
2. Barrel Nuts	5. Pivot Sleeve	8. Balance bar
3. Jam-nut	6. Spherical Bearing	9. Jam-nuts (Pushrod)

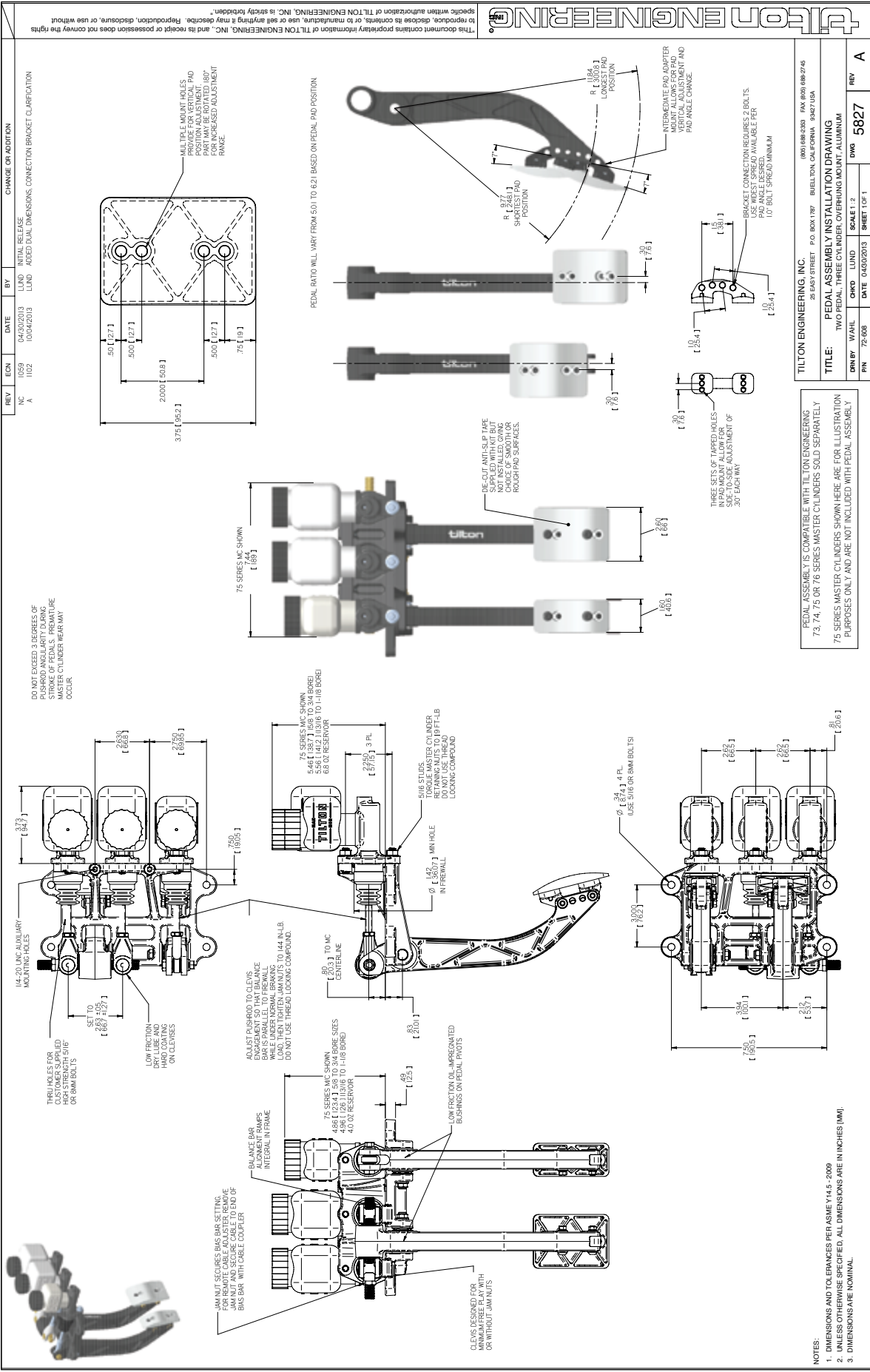

DO NOT EXCEED 3 DEGREES OF PUSHROD ANGULARITY DURING STROKE OF PEDALS. PREMATURE MASTER CYLINDER WEAR MAY OCCUR.

144-20 UNC AUXILIARY MOUNTING HOLES

THRU HOLES FOR LUBE AND HIGH STRENGTH 5/16" OR BMW BOLTS

SET TO 2.63 (66.8) ± 0.02 (0.51)

LOW FRICTION DRY LUBE AND LUBRICATION ON CLEARANCES

ADJUST OVERLOAD TO CLEAR ENVOUCHMENT SO THAT BALANCE BAR IS PARALLEL TO FIREWALL

LOAD TIGHTEN JAM NUTS TO 144 IN-LB LOAD. DO NOT USE THREAD LOCKING COMPOUND.

BALANCE BAR IS PARALLEL TO MC CENTERLINE

JAM NUT SECURES BIASE BAR SETTING. LOCKS CABLE AND CABLE COUPLER TO BIASE BAR WITH CABLE COUPLER

75 SERIES MC SHOWN [189]

546 [136.7] (5/8 TO 3/4 ERBEI) 6.6 (0.26)

75 SERIES MC SHOWN [189]

546 [136.7] (5/8 TO 3/4 ERBEI) 6.6 (0.26)

5/16 STUDS. TORQUE MASTER CYLINDER TO 144 IN-LB TORQUE. DO NOT USE THREAD LOCKING COMPOUND.

Ø 1.875 (1/2) MIN HOLE IN FIREWALL

90 TO MC CENTERLINE

75 SERIES MC SHOWN [189]

488 [123.4] (5/8 TO 3/4 ERBEI) 4.0 (0.16)

LOW FRICTION DIL-IMPREGNATED BEARING SPHERICAL PROTS

GLUE RESERVES FOR MINIMUM FREE PLAY WITH OR WITHOUT JAM NUTS

DE-GLUE AND GRIP TAPE SUPPLIED WITH KIT BUT NOT INSTALLED. CHANGING ROUGH PAD SURFACES

75 SERIES MC SHOWN [189]

40.0 (1.57)

0.83 (0.21)

7.75 (0.31)

2.00 [50.8]

500 [12.7]

500 [12.7]

3.75 [95.2]

75 [1.9]

500 [12.7]

MULTIPLE MOUNT HOLES PROVIDED FOR VERTICAL ADJUSTMENT OF PEDAL PART MAY BE ROTATED 180° FOR INCREASED ADJUSTMENT RANGE.

75 SERIES MC SHOWN [189]

546 [136.7] (5/8 TO 3/4 ERBEI) 6.6 (0.26)

75 [1.9]

500 [12.7]

500 [12.7]

3.75 [95.2]

75 [1.9]

500 [12.7]

PEDAL RATIO WILL VARY FROM 5.01 TO 6.21 BASED ON PEDAL PAD POSITION.

75 [1.9]

7.75 [0.31]

1.88 [47.8]

R 1.38 [35.0]

R 9.77 [248.0]

INTERMEDIATE PAD ADAPTER FOR VERTICAL ADJUSTMENT AND PAD ANGLE CHANGE.

75 [1.9]

3.0 [76.2]

THREE SETS OF TAPPED HOLES FOR SIDE-TO-SIDE ADJUSTMENT OF .30" EACH WAY

1.0 [25.4]

1.5 [38.1]

BRACKET FRAMEWORK REQUIRES 2 BOLTS. USE WIDEST SPREAD AVAILABLE PER PAD ANGLE DESIRED.

1.0 [25.4]

10" BOLT SPREAD MINIMUM

75 [1.9]

1.0 [25.4]

1.0 [25.4]

1.0 [25.4]

75 [1.9]

40.0 (1.57)

Ø 1.875 (1/2) ± 0.004 (0.10)

USE 5/16 OR BMW BOLTS

1.5 [38.1]

2.63 [66.8]

3.00 [76.2]

1.5 [38.1]

1.0 [25.4]

1.0 [25.4]

1.0 [25.4]

1.0 [25.4]

1.0 [25.4]

1.0 [25.4]

1.0 [25.4]

1.0 [25.4]

1.0 [25.4]

1.0 [25.4]

1.0 [25.4]

1.0 [25.4]

1.0 [25.4]

1.0 [25.4]

1.0 [25.4]

1.0 [25.4]

1.0 [25.4]

1.0 [25.4]

1.0 [25.4]

1.0 [25.4]

1.0 [25.4]

1.0 [25.4]

1.0 [25.4]

1.0 [25.4]

1.0 [25.4]

1.0 [25.4]

1.0 [25.4]

1.0 [25.4]

CHANGE OR ADDITION

REV	EON	DATE	BY	INITIAL RELEASE
NC A	1059 1022	04/02/2013 10/04/2013	LJND	ADDED DUAL DIMENSIONS, CONNECTION BRACKET CLARIFICATION

This document contains proprietary information of TILTON ENGINEERING, INC., and its receipt or possession does not convey the rights specific written authorization of TILTON ENGINEERING, INC. is strictly forbidden. No part of this publication may be reproduced, stored in a retrieval system, or transmitted in any form or by any means, electronic, mechanical, photocopying, recording, or by any information storage and retrieval system, without the prior written permission of Tilton Engineering, Inc.

TILTON ENGINEERING

TILTON ENGINEERING, INC.  
803/488-2300 FAX 488-2745  
25 EASY STREET P.O. BOX 1787 BUELLTON, CALIFORNIA 93427 USA

TITLE: PEDAL ASSEMBLY INSTALLATION DRAWING  
TWO PEDALS, THREE CYLINDER, COVERING HOOD, ALUMINUM

DWG #	WAHL	DWG	LJND	SCALE: 1:1	SHEET 1 OF 1	REV
PN	72-808	DATE	04/02/2013			A

NOTES:  
1. DIMENSIONS AND TOLERANCES PER: ASME Y14.5-2009  
2. UNLESS OTHERWISE SPECIFIED, ALL DIMENSIONS ARE IN INCHES (MM).  
3. DIMENSIONS ARE NOMINAL.