

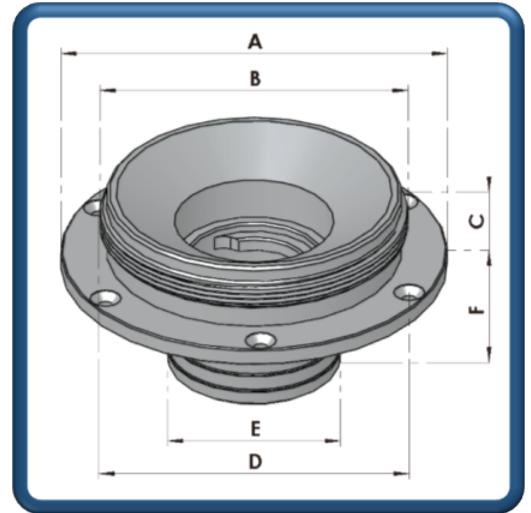

Classic 350

**Classic 3.50" Ø51.0mm Flange Neck.
Part Number: FL-AG-002 (CFN3550)**



Specifications:

Options:
Fixing Arrangement:
Applications:
Compatibilities:

Finish:
Weight:
Supplied With:

N/A
6 x M5 CSK Bolts
Fuel, Oil & Water Tanks
Compatible with Add Blue
Operation Temperature -40°C to +80°C
Anodise Silver +AA6 BS EN ISO 7599
195.0 grams
Flange Neck
M5 Screw Pack
Gasket

Materials:

Flange:
Screw Pack:
Gasket:

Aluminium Alloy 6082/T6
A2 Type Stainless Steel
NBR Cork

Dimensions:

Outer Dimension A:
Thread Specifications B:
Height C:
PCD D:
Hose Spigot Diameter E:
Hose Spigot Height F:

126.0mm
3.5" x 11TPI BSP Thread
22.0mm
6 x M5 CKS Holes on a 114.3mm PCD
Ø51.0mm
26.0mm

Optional('s):

Viton A Gasket
Lead-Free Flap
Locking Insert
Classic 3.5" Cap
Ø51.0 Straight Hose 1m
Ø51.0 Angle Hose 45°
Ø51.0 Angle Hose 90°