

NOTES:

1. THIS DRAWING DESCRIBES THE FUELAB 535xx SERIES MINI FUEL PRESSURE REGULATOR.
2. FEATURES INCLUDE:
 - TWO -10AN INLET PORTS (ON EITHER SIDE OF REGULATOR)
 - ONE -10AN RETURN PORT (ON BOTTOM OF REGULATOR)
 - AVAILABLE IN PRESSURE RANGES: "C", "T", "E" AND "G"
 - BILLET ALUMINUM, STAINLESS STEEL CONSTRUCTION WITH FLUOROSILICONE DIAPHRAGM AND SEALS. PLUG AND FITTING ARE MADE OF UNPLATED BRASS.
3. FUEL COMPATIBILITY INCLUDES:
 - GASOLINE (PUMP OR RACE)
 - METHANOL
 - ETHANOL (INCLUDING E85)
 - DIESEL
4. UNIQUE SERIAL NUMBER DOES NOT CONTAIN DIRECT INFORMATION IN DETERMINING MODEL NUMBER. CONTACT FUELAB FOR DETERMINATION OF MODEL NUMBER BASED ON SERIAL NUMBER.
5. BRACKET, PRESSURE ADJUSTMENT HARDWARE, BRACKET MOUNTING HARDWARE, GAUGE PORT PLUG, BARBED FITTING, 3X -906 PORT O-RINGS AND INSTRUCTIONS INCLUDED, BAGGED SEPARATELY FROM REGULATOR.
6. SEE TABLES BELOW FOR DETERMINATION OF DESIRED MODEL NUMBER.
7. RATED FLOW CAPACITY IS A FUNCTION OF PRESSURE SETTING AS WELL AS RETURN LINE SIZE AND CONFIGURATION, THEREFORE FLOW CAPACITY MAY BE HIGHER OR LOWER, BUT REPRESENTS TYPICAL CAPACITY. REGULATION SLOPE REFERS TO CHANGES IN FUEL PRESSURE AS A FUNCTION OF CHANGES IN FLOW RATE. AS THE AMOUNT OF FUEL RUNNING THROUGH THE REGULATOR REDUCES, THE REGULATED PRESSURE WILL LOWER, SPECIFIED BY THE REGULATION SLOPE.
8. FOR TYPICAL EFI APPLICATIONS, PRESSURE REFERENCE PORT IS PLUMBED TO THE ENGINE'S INTAKE MANIFOLD. CHANGES IN AIR PRESSURE AT THIS PORT WILL RESULT IN A CHANGE IN FUEL PRESSURE AT A RATIO OF 1:1.

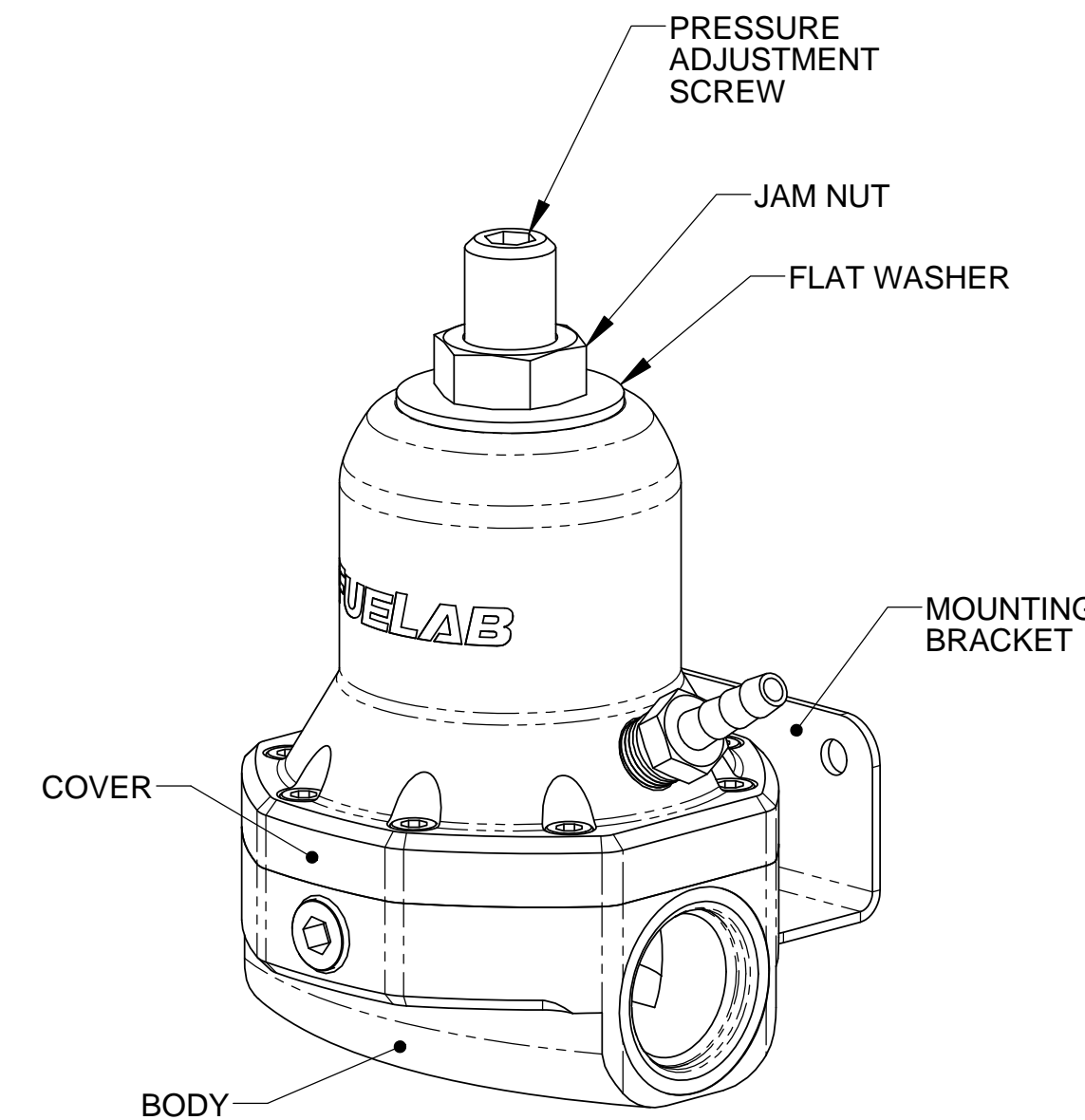
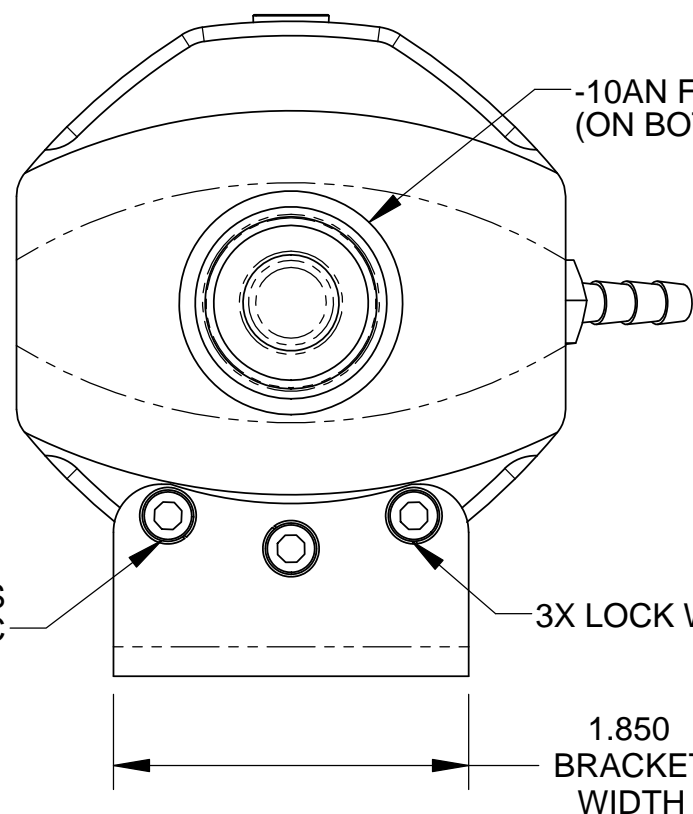
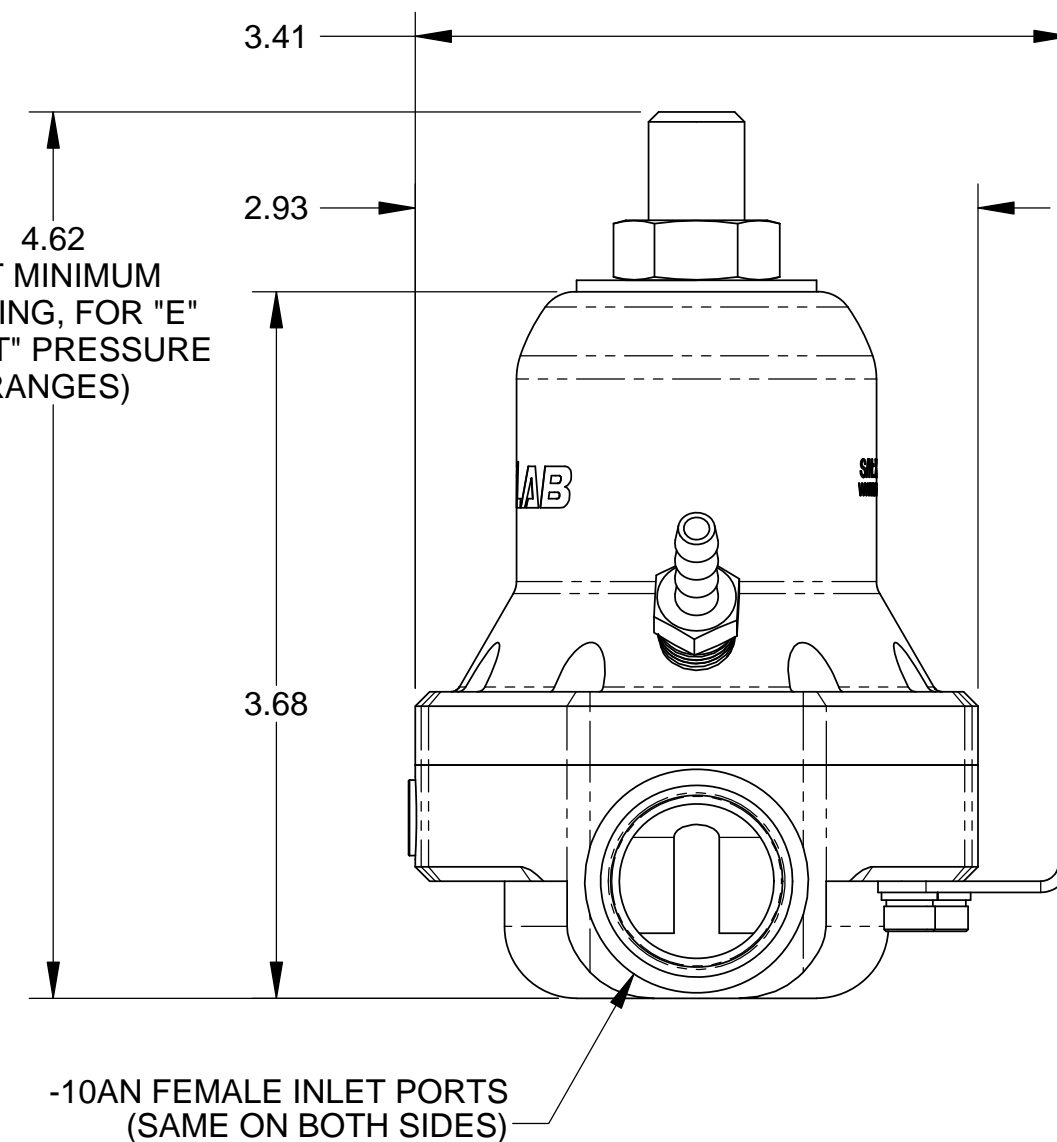
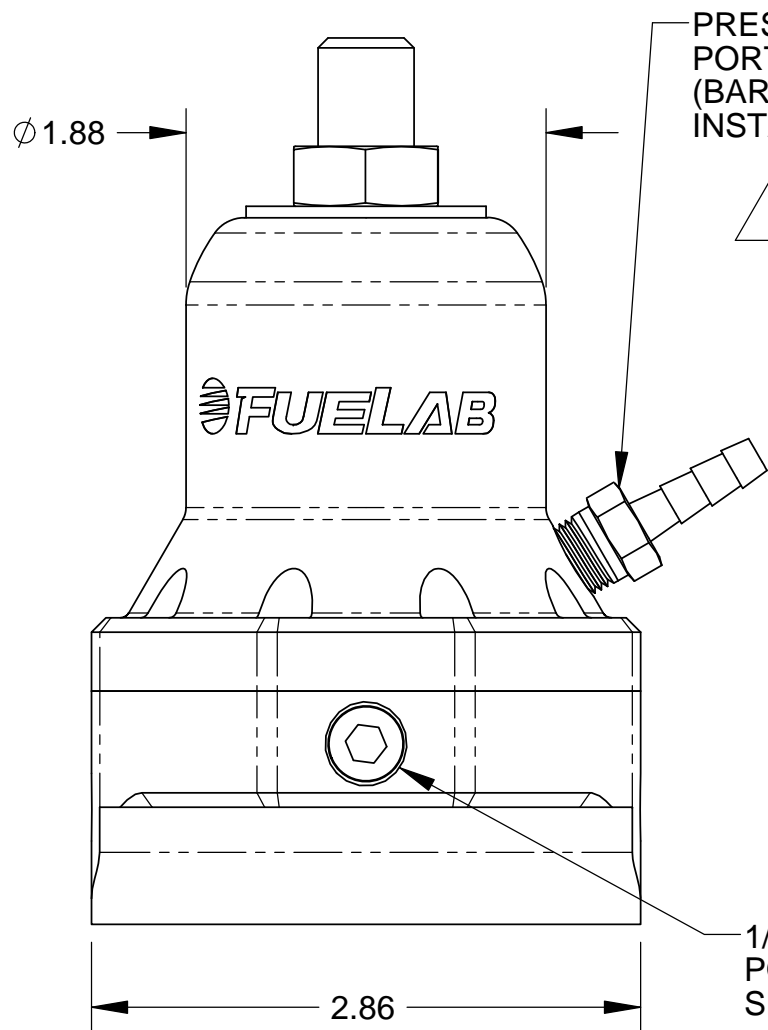

MODEL NUMBER SCHEME:

56501 - c
 c = COLOR CODE
 STANDARD EFI FUEL PRESSURE REGULATOR

56503 - c
 c = COLOR CODE
 THROTTLE BODY / OTHER FUEL PRESSURE REGULATOR

56502 - c
 c = COLOR CODE
 STANDARD CARBURETED FUEL PRESSURE REGULATOR

56504 - c
 c = COLOR CODE
 HIGH PRESSURE EFI FUEL PRESSURE REGULATOR

PRESSURE RANGE

MODEL	APPROX. PRESSURE RANGE	APPROX. FLOW CAPACITY	REGULATION SLOPE
56501-c	25-65 PSID (1.7-4.5 Bar)	8.0 GPM (1800 LPH)	< 1 PSI/GPM
56502-c	4-12 PSID (0.28-0.82 Bar)	5.0 GPM (1100 LPH)	< 0.5 PSI/GPM
56503-c	10-25 PSID (0.7-1.7 Bar)	5.0 GPM (1100 LPH)	< 1 PSI/GPM
56504-c	40-85 PSID (2.75-5.8 Bar)	8.0 GPM (1800 LPH)	2.3 PSI/GPM

COLOR CODE, c

c	COVER COLOR	BODY COLOR
1	BLACK	BLACK
2	RED	CLEAR
3	BLUE	CLEAR
4	PURPLE	CLEAR
5	GOLD	BLACK
6	GREEN	CLEAR

**ISOMETRIC VIEW
 (ALL VIEWS SHOWN
 WITH HARDWARE
 INSTALLED)**

UNLESS OTHERWISE SPECIFIED:
 INTERPRET DWG PER ANSI Y14.5
 DIMENSIONS ARE IN INCHES
 TOLERANCES:
 FRACTIONAL: ±1/64"
 ANGULAR: ±1/2°
 DECIMALS:
 X±1 .XX±0.03 .XXX±0.010
 SURFACE FINISH: 128 OR BETTER
 BREAK ALL SHARP EDGES: 010 MAX
 REMOVE ALL BURRS

THIRD ANGLE PROJECTION

DO NOT SCALE DRAWING

FUELAB
 DIGITAL FUEL DELIVERY Litchfield, Illinois

TITLE:
**REGULATOR,
 565xx SERIES**

SIZE: **C** DWG. NO.: **105020600** REV: _____

SCALE: 1/1 WEIGHT: _____ SHEET: 1 OF 1