

TILTON 79 SERIES MASTER CYLINDER REBUILD INSTRUCTIONS

DISASSEMBLY:

- 1.) In a vice with aluminum soft jaws, firmly clamp the parallel flat sides of the master cylinder Body around the Spherical Bearing.
- 2.) Remove any fitting or plug from the outlet port (closest to the spherical bearing).
- 3.) Remove the AN-3 flush plug from the vertical port.



Note: cartridge valve and components below flush plug are not serviceable. These are permanently installed at the factory and cannot be removed, only cleaned.

- 4.) Remove any swivel type fitting or line from the angled inlet port by expanding the retaining ring with expanding retaining ring pliers until the fitting can clear the inner diameter.
- 5.) Remove the Rubber Boot (74-401M) by pulling it off of the Piston Guide and Piston Push Rod.
- 6.) Compress the conical Compression Spring (78-3301-1) and Spring Retainer (78-3300) to expose the Wire Lock Ring (78-3302).
- 7.) Expand the Wire Lock Ring and remove from the Piston Push Rod.
- 8.) Remove the Spring Retainer and Spring.
- 9.) Using a 1.25" deep socket, loosen the Piston Guide (78-31X) (hex shape, right hand threads).

[NOTE: Piston Guides are made in incremental lengths and used specifically to set the cutoff port travel. Keep components from each master cylinder as a matched set. Cutoff port travel .030-.050" and documented on the label decal on bottom of units.]

- 10.) Completely unscrew the Piston Guide from the Body. Be careful near the last thread, as an internal spring will push the assembly apart.
- 11.) Slide the Piston Guide off of the Pushrod.
- 12.) Using a right angle pick, remove the main Pressure Seal (7X-31X) from the Piston (Take care not to damage or lose the thin shim washer behind main pressure seal).
- 13.) Using the same pick or similar tool remove the 77-005 Piston Guide Seal (77-005) and larger O-ring (78-3200) from the Piston Guide. Do not scratch seal glands when removing.
- 14.) Discard of the following parts:
 - 7X-31X Pressure Seal (1)
 - 77-005 Piston Guide Seal (1)
 - 75-010 Internal Compression Spring (1)
 - 75-020 Rod, Spring Guide (1)
 - 75-06X Shim Washer (1)
 - 78-3200 O-ring (1)
 - 78-3302 Wire lock ring (1)
 - 7/16 external Retaining Ring (1)
 -

CLEANING / PREPARATION

- Be careful not to scratch remaining parts, clean in aqueous parts washer or equivalent. It is ok to use shop air to dry and blow off components.

- 1) Inspect the 3 small holes in the head of the Piston Push Rod for debris. Use a small pick or drill bit to clear the holes if necessary.
- 2) Inspect the deep hole in the center of the Piston Push Rod.
- 3) Wipe any remaining residue from all features of the Piston Push Rod.
- 4) If necessary, clean any oil from the master cylinder Body. Use NEW Simple Green or Alcohol because any grit in the cleaning solution may plug the very tiny passages in the Master Cylinder Body.

ASSEMBLING THE MASTER CYLINDER:

- 4) Lightly apply rubber grease to the head and seal groove of the Piston Push Rod.
- 5) Place the thin Shim on the head of the Piston followed by the Pressure Seal. Make sure the ID of the Pressure Seal is fully seated in the small diameter area of the Piston. You may need to work the ID edge of the seal down with your fingernail or blunt tool.
- 6) Check that the thin Shim is centered on its register on the Piston.
- 7) Install the 77-005 Seal into the Piston Guide by folding the seal into a kidney shape and inserting into the bore. The seal is a loaded U cup and should be positioned so that the U shape is open towards the inside of the bore with the o-ring. (Note, o-ring comes preinstalled into the U cup seal to energize the sealing lips.) Rubber grease will help the installation. Make sure it is fully seated and that the o-ring did not move out of position.
- 8) Install the large outer O-ring onto the Piston Guide.
- 9) Slide the Piston Guide onto the piston push rod until the tip is at the 77-005 seal. Thread the Piston Guide and Seal onto the Piston Push Rod so that the Seal lip does not get damaged. Once past the threaded section, push the Piston Guide down onto the Push Rod shaft.

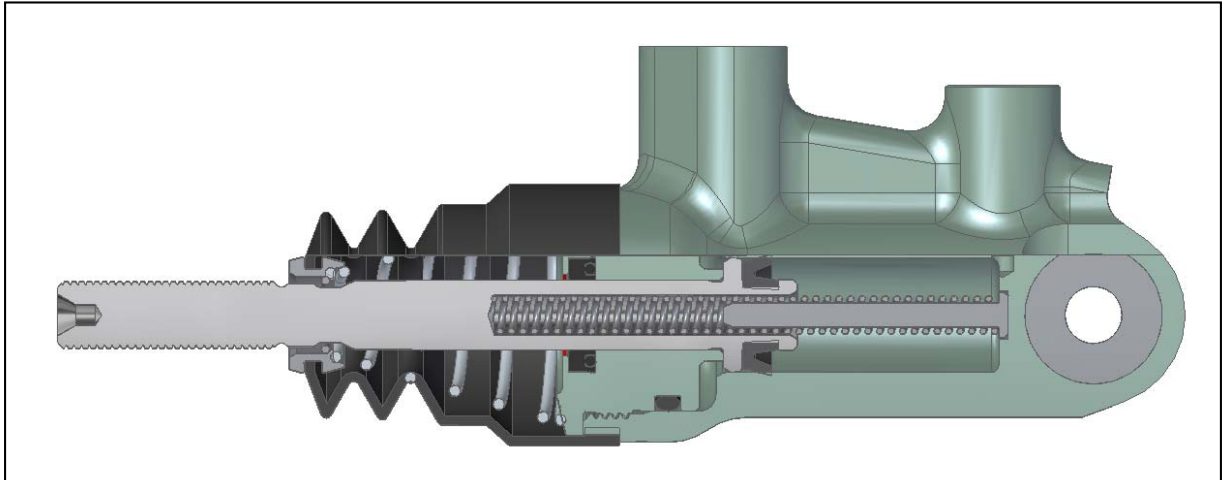

10) Insert the Rod and Spring into the drilled counterbore in the Piston Push Rod, leaving it hanging part way out.

11) Lightly apply rubber grease to the Pressure Seal and Piston Guide O-ring. Gently insert the Piston into the Body. As you do so, make sure the Spring and Rod are registered by the counterbore at the bottom of the Body bore.

12) Hand tighten the Piston Guide into the Body. If the Piston Guide will not thread down, check the alignment of the Spring and Rod in the counterbore of the Body.

13) Torque the Piston Guide to 20 ft-lbf.

14) Confirm that the Piston Push Rod moves in and out freely.

15) Apply rubber grease to the Piston Push Rod shaft. (Boot will cover and retain this grease.)

16) Install the Conical Compression Spring and Spring Retainer (note direction) onto the Push Rod.

17) Expand the Wire Lock Ring and install over the Piston Push Rod shaft. Compress the Spring and Retainer down past the second groove and wrench flats on the Piston Push Rod shaft. Squeeze the Wire Lock Ring into a closed circle shape and compress/guide it into the counterbore ID of the Spring Retainer. The Wire Lock Ring should register against the taper of the groove past the wrench flats.

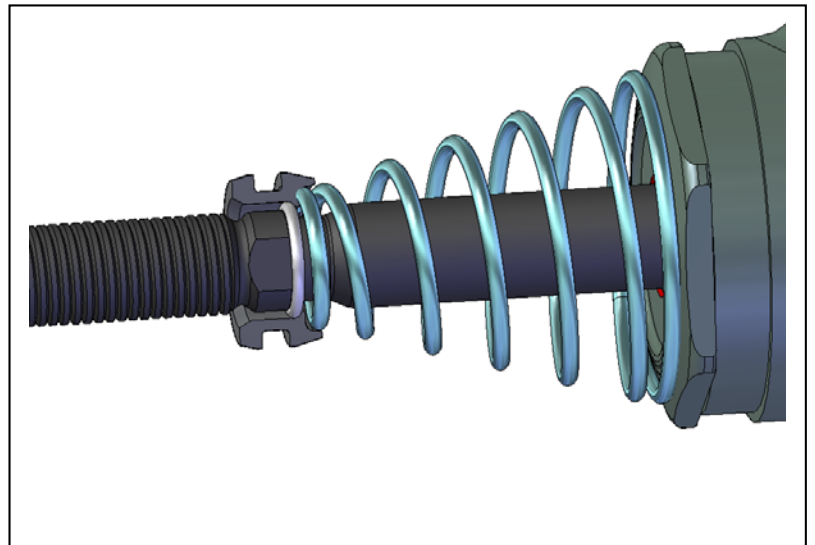

18) Install the Rubber Boot onto the shaft and over the Spring and Spring Retainer. Stretch the large end of the Boot over the hex of the Piston Rod Guide (A small amount of rubber grease on the inside of the boot will aid in installation). Stretch the ID of the small end of the Boot and register it into the groove on the Spring Retainer.

19) Confirm that the Piston Push Rod compresses and extends.

20) Install the AN-3 flush Plug (73-825) into the vertical front port (next to angled inlet) and torque to 144 in-lb.

21) Slide the 7/16 Retaining Ring (5100-43) into the slot in the angled inlet port with sharp edge down, rounded edge side up. Inspect the small o-ring on the inlet fitting/line. Add grease to the o-ring and install through the center of the Retaining Ring. Push down hard to expand Retaining Ring and make sure it seats on the small step of the fitting, locking it in place.

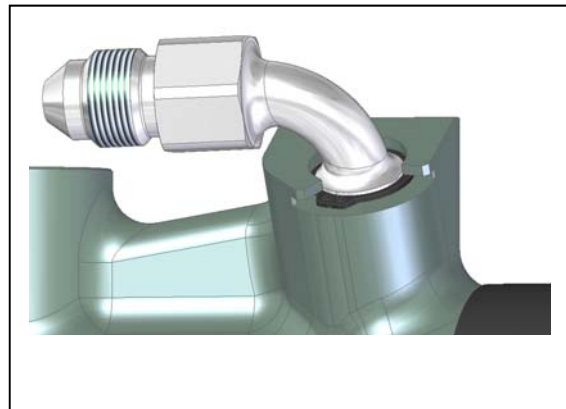
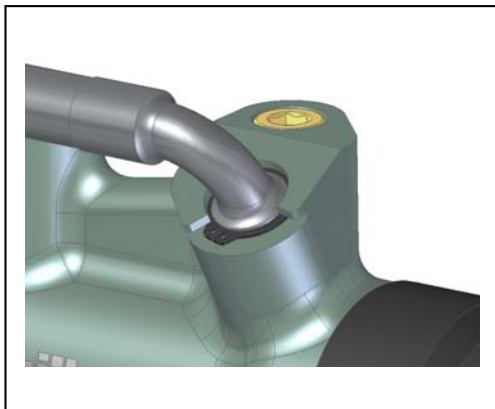

21) Apply new sticker decal and label as desired. Sticker has clear cover flap that can be applied over the users written notes once flap backing is peeled off. (Sticker decal may be trimmed to fit as desired)

PARENT PART NUMBER	BODY P/N	PISTON GUIDE P/N	SHIM P/N	PISTON P/N	PRESSURE SEAL P/N
79-625	79-110	78-312	75-060	77-210	75-310
79-700	79-111	78-312	75-061	77-211	79-311
79-750	79-112	78-312	75-062	77-212	75-312
79-812	79-113	78-312	75-063	77-213	75-313
79-875	79-114	78-312	75-064	77-214	75-314
79-937	79-115	78-312	75-065	77-215	75-315
79-1000	79-116	78-312	75-066	77-216	75-316

ZONE	CHK'D	DATE	REV	ECN	CHANGE OR ADDITION

This document contains proprietary information of TILTON ENGINEERING, INC., and its receipt or possession does not convey the rights to reproduce, disclose its contents, or to manufacture, use or sell anything it may describe. Reproduction, disclosure, or use without specific written authorization of TILTON ENGINEERING, INC. is strictly forbidden.

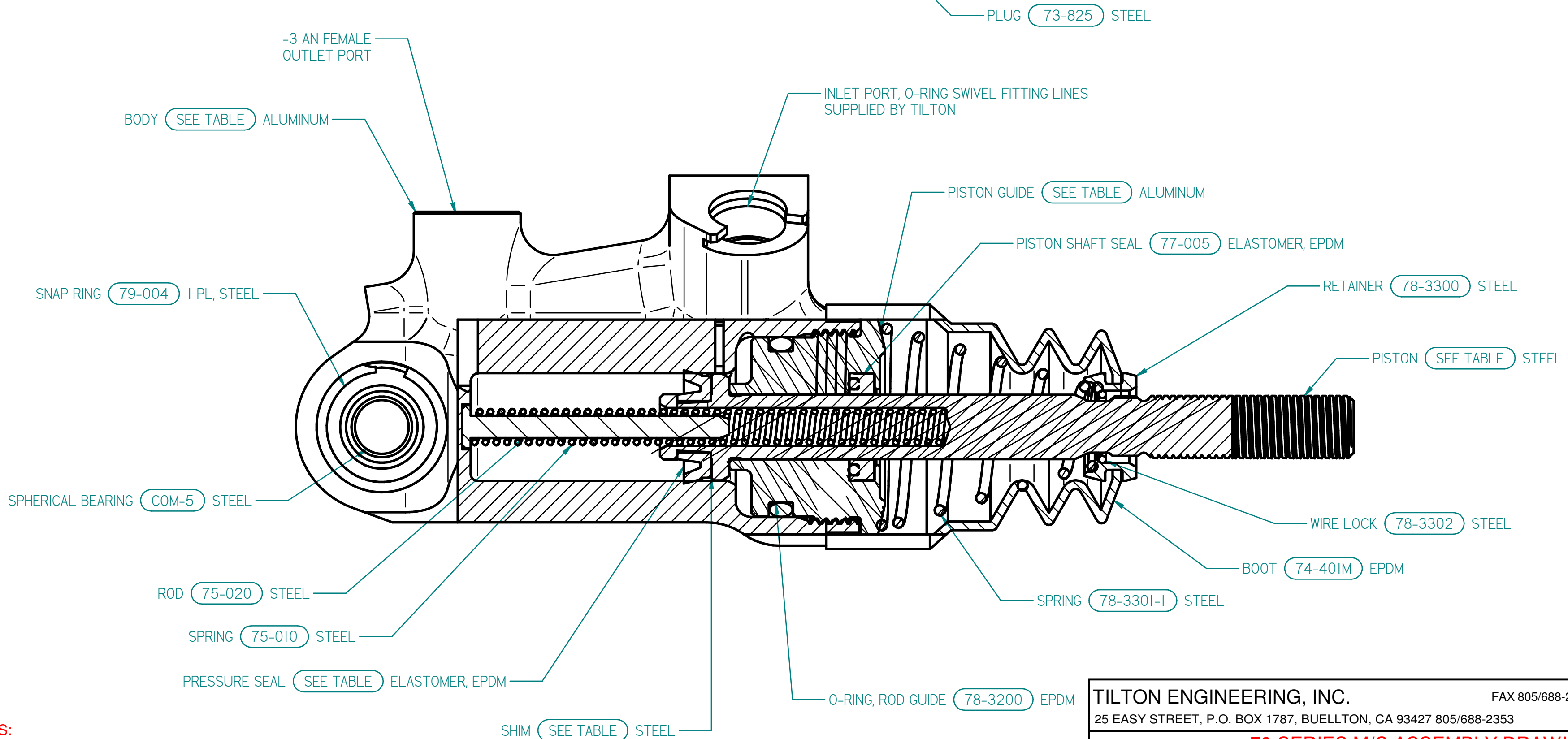
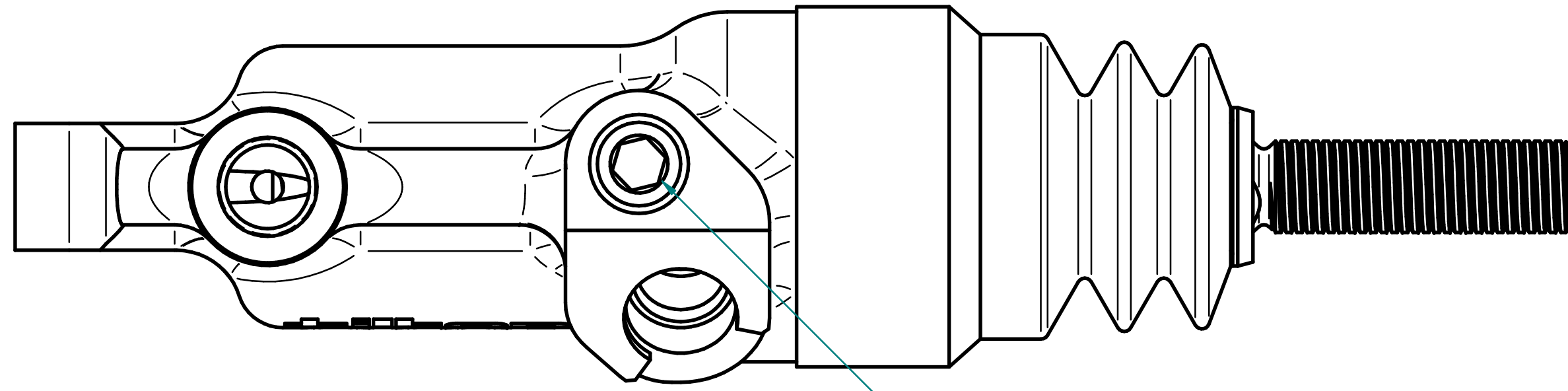

NOTES:
 1. DIMENSIONS AND TOLERANCES PER ASME Y14.5 - 2009
 2. UNLESS OTHERWISE SPECIFIED, ALL DIMENSIONS ARE IN INCHES [MM].

TILTON ENGINEERING, INC.			FAX 805/688-2745		
25 EASY STREET, P.O. BOX 1787, BUELLTON, CA 93427 805/688-2353					
TITLE: 79 SERIES M/C ASSEMBLY DRAWING			ALL BORE SIZES		
DRAWN BY LUND	CHKD WAHL	SCALE 2 : 1	SIZE DWG	REV	
P/N SEE TABLE	DATE 3/30/2017	SHEET 1 OF 2	C 6553	C	

TILTON ENGINEERING[®]

ZONE	CHK'D	DATE	REV	ECN	CHANGE OR ADDITION
------	-------	------	-----	-----	--------------------

-3 AN FEMALE
OUTLET PORT

.375
[9.52]
SPHERICAL BEARING WIDTH

Ø .142
[3.607]

1.250
[31.75]

3/8 x 24 THREAD

2.170
[55.12]

1.26
[32.08]

Ø .312
[7.94] THRU
SPHERICAL BEARING

.50

5.65
[143.41] AT REST
1.06 [26.9] MAX STROKE

tilton
P/N: XX-XXX XX/XX" DCCmm
S/N MMYY-XXXX

NOTES:

1. DIMENSIONS AND TOLERANCES PER ASME Y14.5 - 2009
2. UNLESS OTHERWISE SPECIFIED, ALL DIMENSIONS ARE IN INCHES [MM].

TILTON ENGINEERING, INC.			FAX 805/688-2745		
25 EASY STREET, P.O. BOX 1787, BUELLTON, CA 93427 805/688-2353					
TITLE:			79 SERIES M/C ASSEMBLY DRAWING		
ALL BORE SIZES					
DRAWN BY	LUND	CHKD	WAHL	SCALE	2 : 1
P/N	SEE TABLE	DATE	3/30/2017	SIZE	DWG
				SHEET	2 OF 2
				C	6553
				REV	C

tiltonENGINEERING[®]
INC.

"This document contains proprietary information of TILTON ENGINEERING, INC., and its receipt or possession does not convey the rights to reproduce, disclose its contents, or to manufacture, use or sell anything it may describe. Reproduction, disclosure, or use without specific written authorization of TILTON ENGINEERING, INC. is strictly forbidden."