

## **Technical Bulletin 042 – FIA TL 16 Data Sheet**

**REV2 23/11/2017**

<b>Other References</b>	
<b>TB009</b>	Extinguisher Selection
<b>TB040</b>	Plumbed-in FIA TL16 Systems – Installation Guide
<b>TB041</b>	FIA TL 16 Systems – Kit Content and Spares
<b>TB020</b>	Motorsport Regulation Changes

### **Overview**

Lifeline FIA Technical List 16 systems are a refinement and improvement of the originals, lowering fire out times by an average of 6 seconds across the whole range and by a massive 7 seconds in the Zero 2000 range\*.

By optimising nozzle design to give increased coverage resulting in faster discharge times, the new Lifeline FIA Technical List 16 range provides increased levels of safety for all competition vehicles.

The entry level Fire Marshal range provides increased fire out performance and cost benefits for a minimal weight penalty. The electric stored pressure systems are pure performance; optimised both for weight and fire out time.

Fastest and lightest are the CD Remote systems. Utilising Lifeline’s proven compression discharge technology, combined with minimal weight & size for ease of packaging. The best choice for formula and sportscars with compact cockpits and tight packaging requirements. By keeping the suppressant separate from the super-pressurising gas these systems also provide the fastest discharge and fire out times with the fewest nozzles for maximum safety and performance.



\*RELATES TO ENGINE TESTS



## Specification

<b>Description</b>	Zero 2000, Zero 360
<b>FIA Homologation</b>	EX.041.17, EX042.17, EX.043.17, EX.044.17
<b>Contents</b>	AFFF, Novec 1230™
<b>Discharge System</b>	Mechanical, Electrical, Remote
<b>Cylinder Material</b>	Steel or Aluminium Alloy
<b>Temperatures</b>	-10 to +60°C

## Weights and Dims

System Number	Type	Capacity	Cylinder Weight	Cylinder Dimensions (Length x Diameter)
106-001-001	FIA TL16 Mechanical	4ltr AFFF	6.6kg	434 x Ø155
106-001-002	FIA TL16 Electric	4ltr AFFF	5.3kg	308 x Ø155
106-001-003	FIA TL16 CD Remote	1.5kg Novec 1230	2.2kg	230 x Ø90
106-001-004	FIA TL16 Mechanical	2.25kg Novec 1230	3.6kg	268 x Ø125
106-001-005	FIA TL16 Electric	2.25kg Novec 1230	3.1kg	235 x Ø125
106-001-006	FIA TL16 CD Remote	2.0kg Novec 1230	2.7kg	219 x Ø108
106-001-007	FIA TL16 Mechanical	3.0kg Novec 1230	4.5kg	324 x Ø125
106-001-008	FIA TL16 Electrical	3.0kg Novec 1230	3.9kg	297 x Ø125
106-001-009	FIA TL16 CD Remote	3.0kg Novec 1230	3.9kg	274 x Ø108

\* PLEASE NOTE: ALL DIMENSIONS AND MASSES ARE BASED ON THE CYLINDER ONLY, THEY DO NOT INCLUDE NOZZLES, TUBING, AND HOSES ETC.

## Fire Out Times

Test	Zero 2000	Zero 360 2.25kg Stored Pressure	Zero 360 3.0kg Stored pressure	Zero 360 2.0kg CD Remote	Zero 360 3.0kg CD Remote	Zero 360 1.5kg CD Remote
<b>Cockpit</b>	14.32s	10.68s	5.06s	7.81s	3.51s	9.67s
<b>Engine Closed</b>	4.99s	5.66s	6.01s	3.05s	2.73s	3.97s
<b>Engine Open</b>	5.16s	5.95s	4.63s	1.72s	2.74s	4.83s

\* PLEASE NOTE: TIMES RECORDING DURING HOMOLOGATION TESTING SHOULD BE CONSIDERED AS INDICATIVE OF PERFORMANCE ONLY AND ARE NOT A GUARANTEE. THE INTENSION OF ANY MOTORSPORT FIRE SUPPRESSION SYSTEM IS TO GIVE THE OCCUPANT A TIME ENVELOPE IN WHICH TO EVACUATE SAFELY.

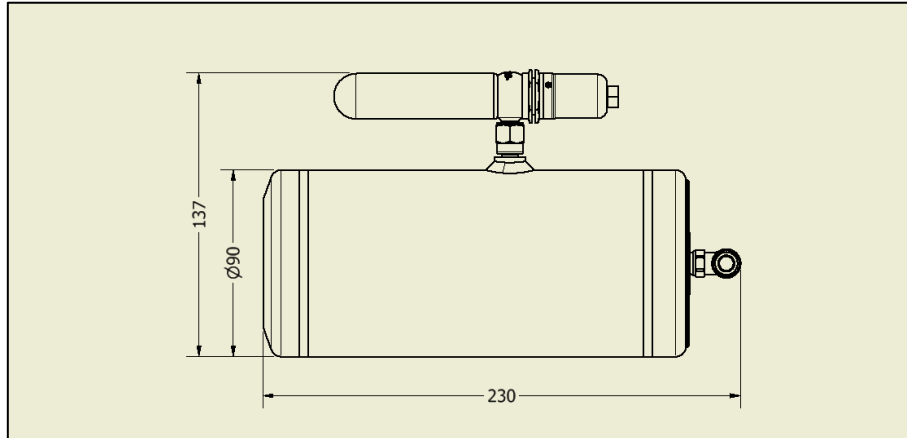

**106-001-003-B Zero 360 1.5kg Remote Charge – CD**  
*(Homologated for single seat race cars and sports prototypes only)*

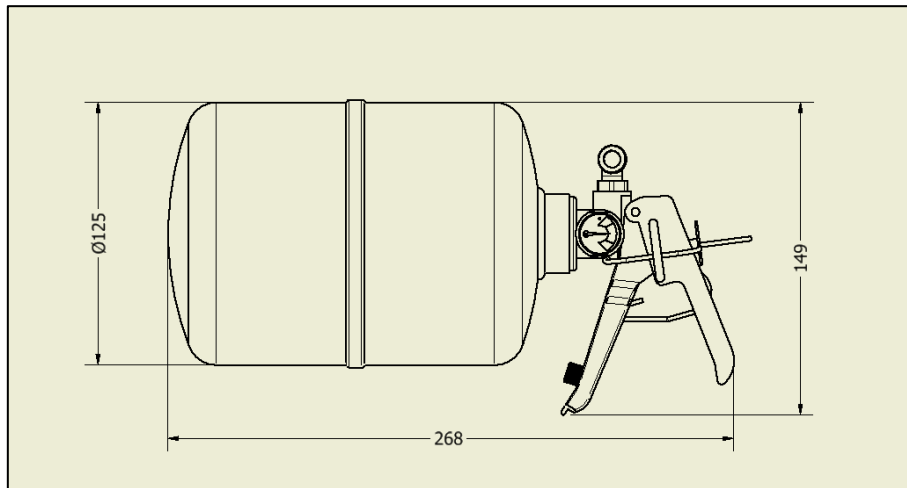

**106-001-004-B Zero 360 2.25kg Fire Marshal**

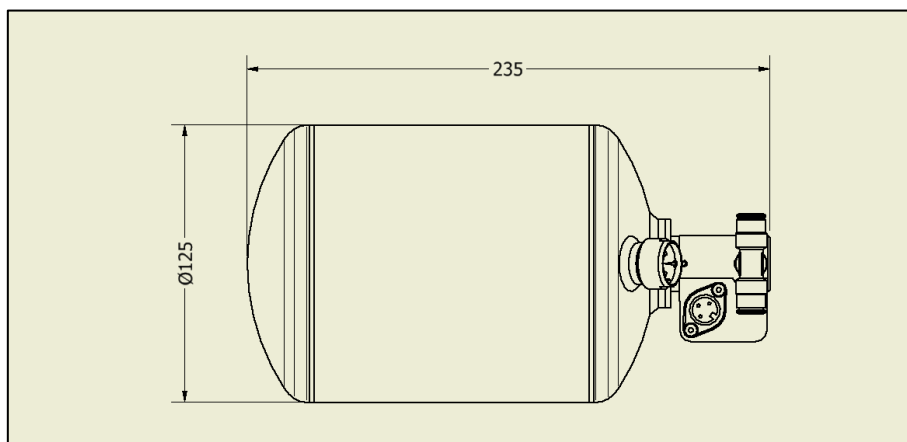

**106-001-005-B Zero 360 2.25kg Electric**

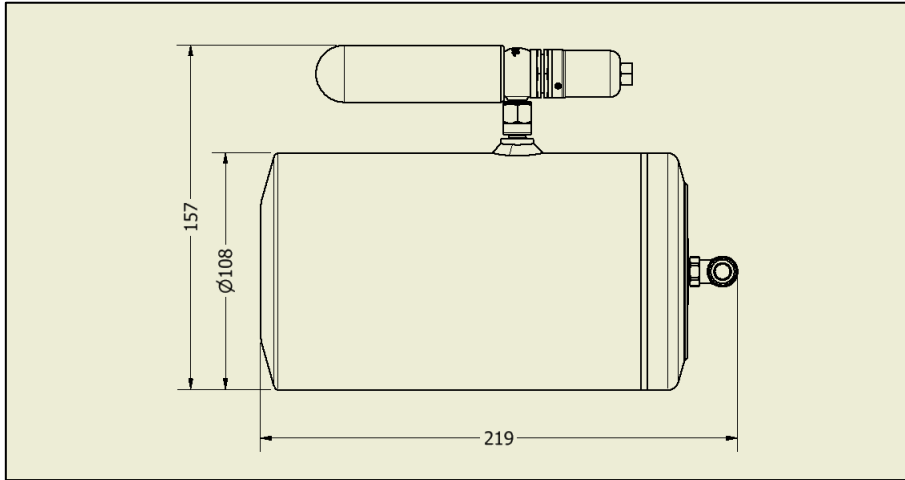

106-001-006-B Zero 360 2.0kg Remote Charge - CD

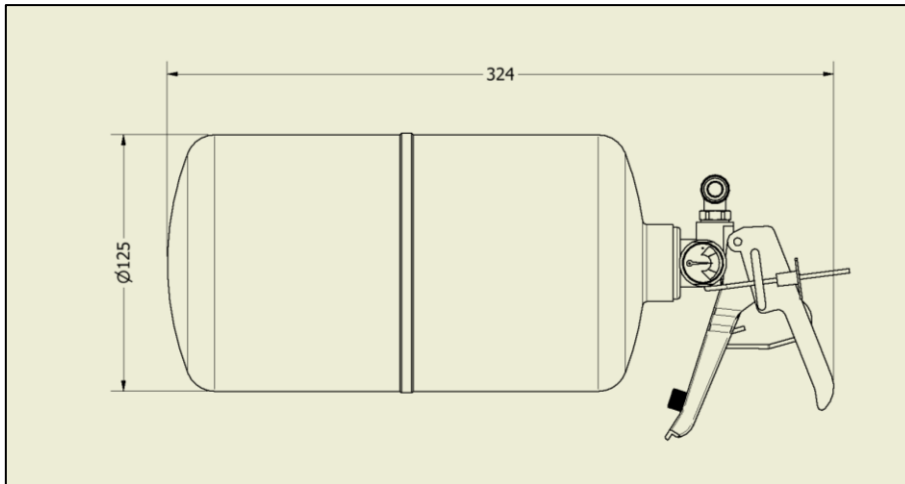

106-001-007-B Zero 360 3.0kg Fire Marshal

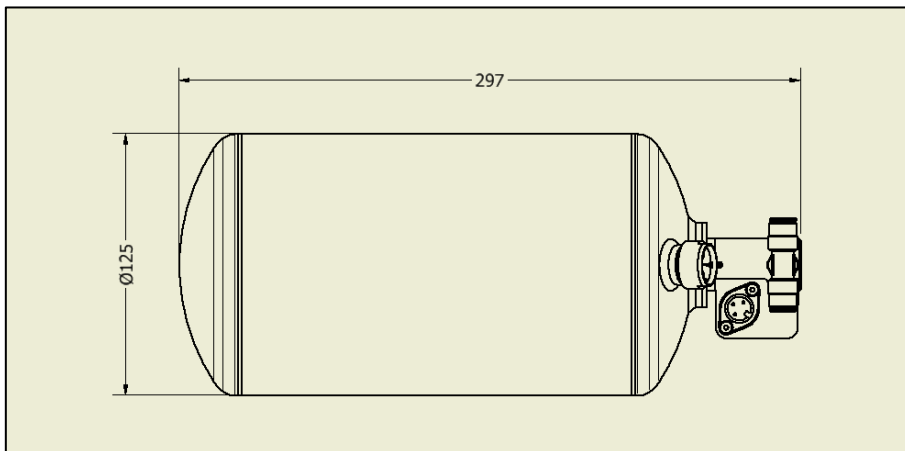

106-001-008-B Zero 360 3.0kg Electric

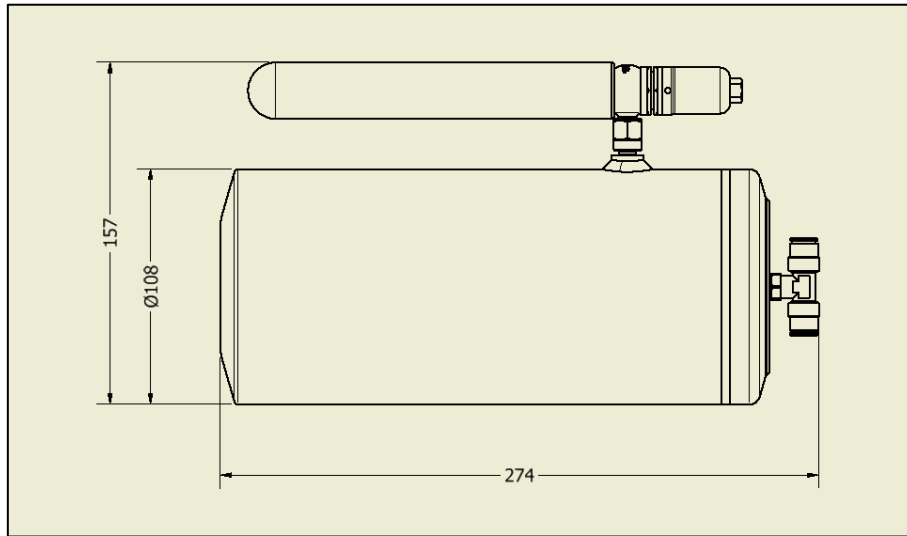

106-001-009-B Zero 360 3.0kg Remote Charge - CD

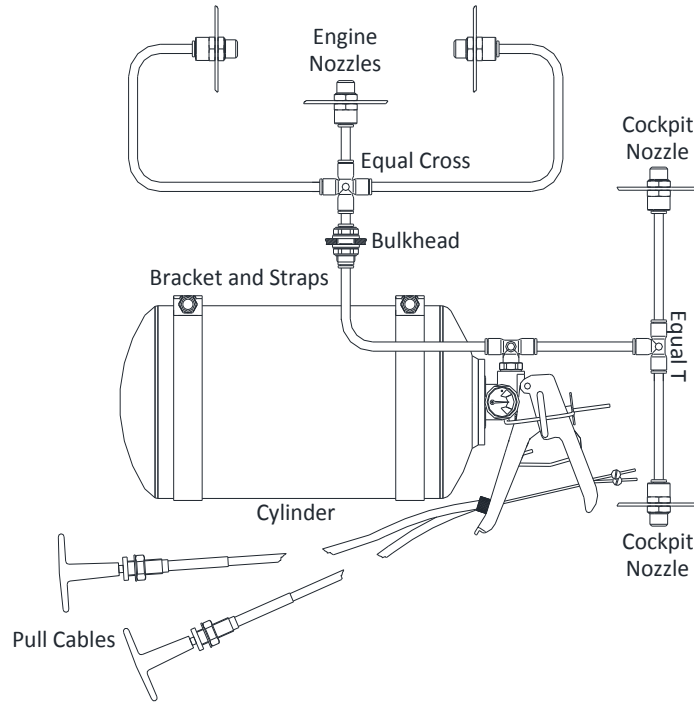

Zero 360 Fire Marshal 106-001-004, 106-001-007

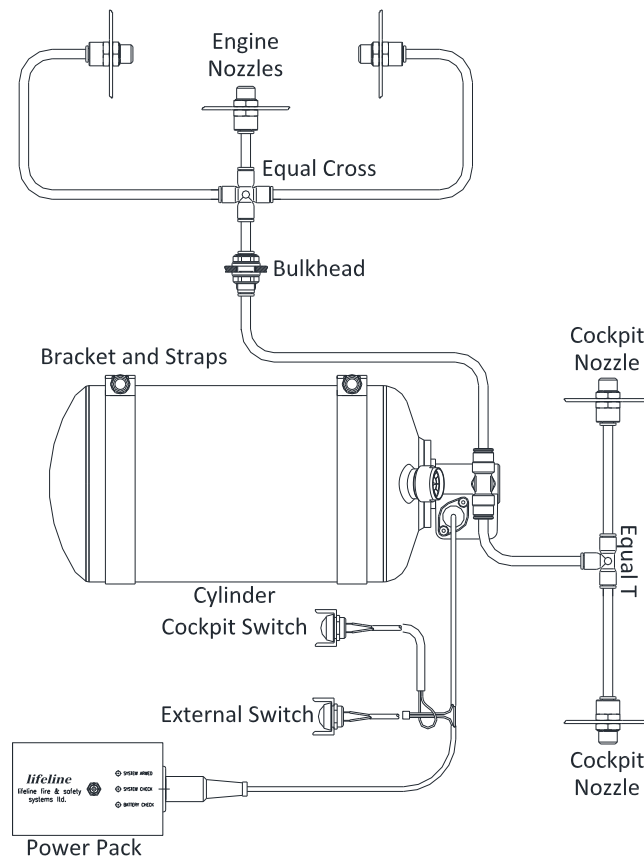

Zero 360 Electrical 106-001-005, 106-001-008

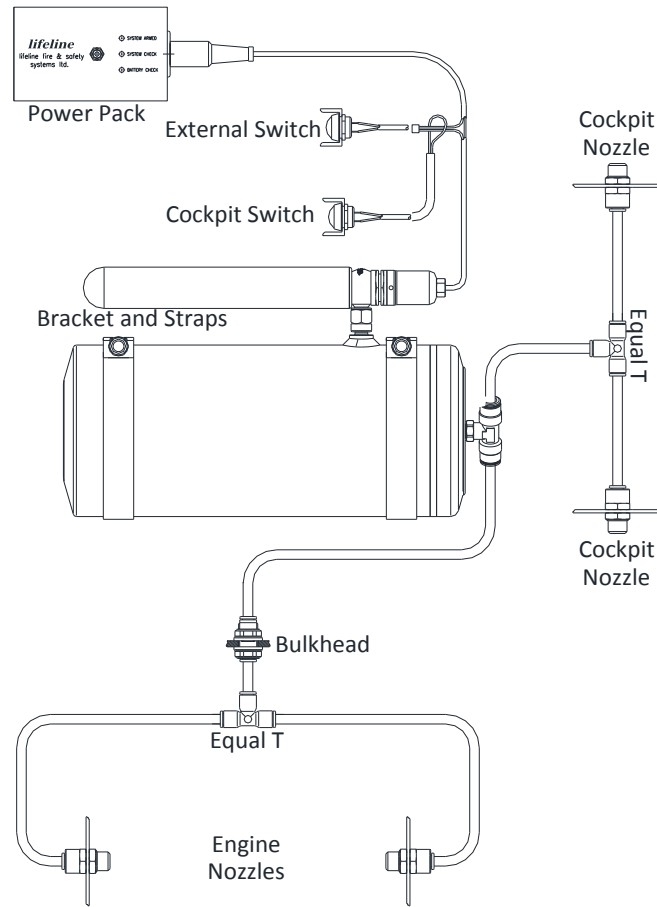

Zero 360 CD Remote Charge CD 106-001-003, 106-001-006, 106-001-009



**Notes**

--	--





Notes

A large empty rectangular box with a black border, intended for notes.