

## EWP® 115 Electric Water Pump 12 & 24 Volt



The world's first universal-fit, automotive Electric Water Pump. Suitable for all makes and models – will excel on large six-cylinder engines.

The EWP® 115 is a practical alternative to the mechanical belt-driven pump or fitted as an auxiliary pump.

### Technical Specifications

	12 Volt Pump	24 Volt Pump
Operating voltage	3V DC to 15V DC	20V DC to 27V DC
Maximum current	10A @ 13V	5.5A @ 24V
Flow rate (max)	115 L/min (30.38 US gal/min) @ 13V DC	115 L/min (30.38 US gal/min) @ 24V DC
Operating temp.	-40° to 130°C (-40° to 266°F)	-40° to 130°C (-40° to 266°F)
Pump design	Clockwise centrifugal with volute chamber	Clockwise centrifugal with volute chamber
Pump weight	1,101 grams (2.43 lb)	1,101 grams (2.43 lb)
Pump material	Aluminium (powder coated)	Aluminium (powder coated)
Burst pressure	500 kPa (72.5 psi)	500 kPa (72.5 psi)
Seal	Ceramic face seal	Ceramic face seal
Fits hose sizes	35mm to 51mm (1 3/8" to 2") - inlet: AN-16 - outlet: AN-16	35mm to 51mm (1 3/8" to 2") - inlet: AN-16 - outlet: AN-16

### Kit Contents

Description	12V	24V	Qty
EWP® 115 Alloy 24 Volt Pump		✓	1
EWP® 115 Alloy 12 Volt Pump	✓		1
Wiring harness	✓	✓	1
Rubber adaptor sleeve - 3mm (1/8")	✓	✓	2
Hose Clamps	✓	✓	2
Assorted hardware bag - includes 12V relay #0533	✓		1
Assorted hardware bag - includes 24V relay #0534		✓	1

### Kit Options (12V & 24V)

Part #	Description	Qty
8505	90° rubber hose adaptor - 38mm (1 1/2") ID	1*
1025	Alloy adaptor AN-16	1*
1024	Alloy adaptor - AN-16	1*
8511	Sleeve 6mm (1/4") rubber adaptor	1*

\* 2 required if using at both ends

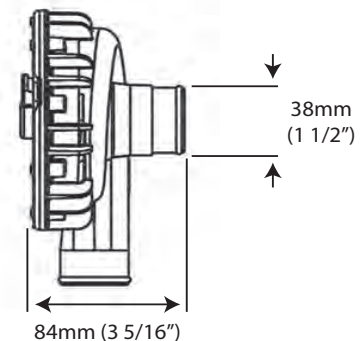
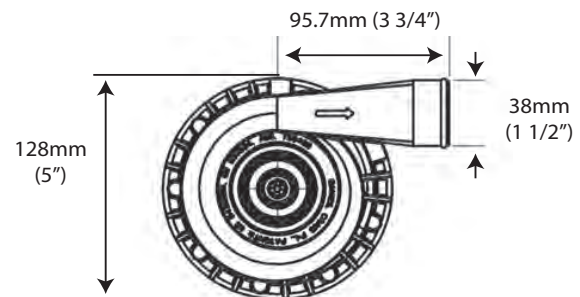

The EWP® is a recirculating pump which is ideal for a 'closed system' similar to an automotive cooling system; it is not 'self-priming'.