

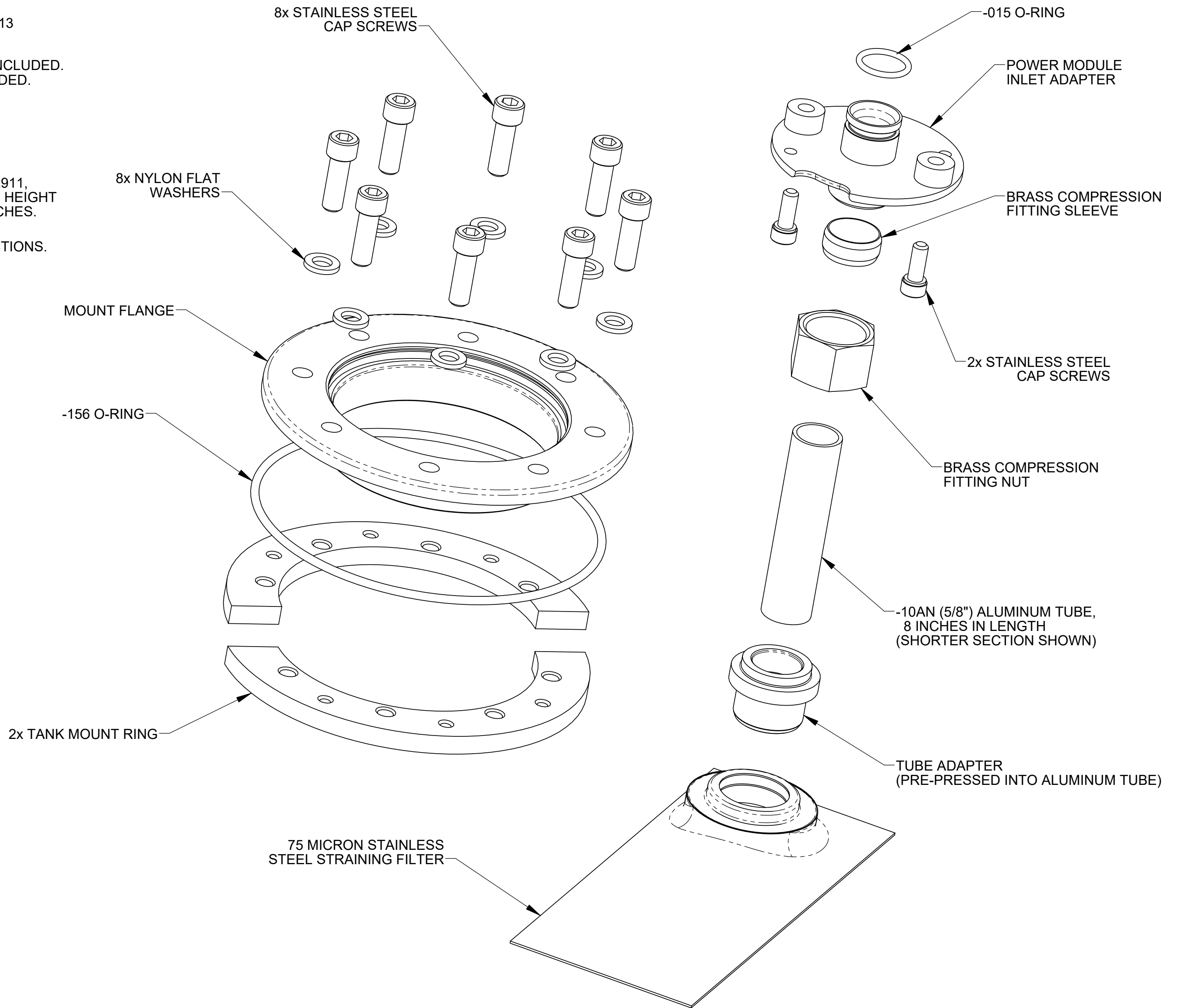

NOTES:

1. THIS DRAWING DESCRIBES THE FUELAB MODEL 20901 FABRICATOR INSTALLATION KIT.
2. FEATURES INCLUDE:
 - FOR USE WITH 90902, 91901, 92902, 92911, 92912 AND 92913 POWER MODULES (NOT INCLUDED).
 - METAL FABRICATION REQUIRED FOR INSTALLATION.
 - MOUNTING FLANGE, HARDWARE AND INLET PLUMBING INCLUDED.
 - STAINLESS STEEL 75 μ RELATIVE RATED ELEMENT INCLUDED.
3. FUEL COMPATIBILITY INCLUDES:
 - GASOLINE (PUMP OR RACE)
 - METHANOL
 - ETHANOL (INCLUDING E85)
 - DIESEL
4. MINIMUM INSTALLATION HEIGHT FOR USE WITH MODELS 92911, 92912 AND 92913 IS 7.875 INCHES. MAXIMUM INSTALLATION HEIGHT FOR USE WITH MODELS 92911, 92912 AND 92913 IS 14.75 INCHES.
5. REFERENCE DRAWING 1490201A1 FOR ASSEMBLY INSTRUCTIONS.

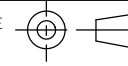

CONTENTS OF INSTALLATION KIT SHOWN ABOVE

UNLESS OTHERWISE SPECIFIED:		 COLLINSVILLE, ILLINOIS	
INTERPRET DWG PER ANSI Y14.5 DIMENSIONS ARE IN INCHES TOLERANCES: FRACTIONAL: ±1/64" ANGULAR: ±1/2° DECIMALS: X±1 .XX±.03 .XXX±.010 SURFACE FINISH: 128 OR BETTER BREAK ALL SHARP EDGES .010 MAX REMOVE ALL BURRS		TITLE: INSTALLATION KIT, MODEL 20901	
THIRD ANGLE PROJECTION 	SIZE C	DWG. NO. 149020100	REV A
DO NOT SCALE DRAWING		SCALE: 1/1	WEIGHT: .95 LB SHEET: 1 OF 2

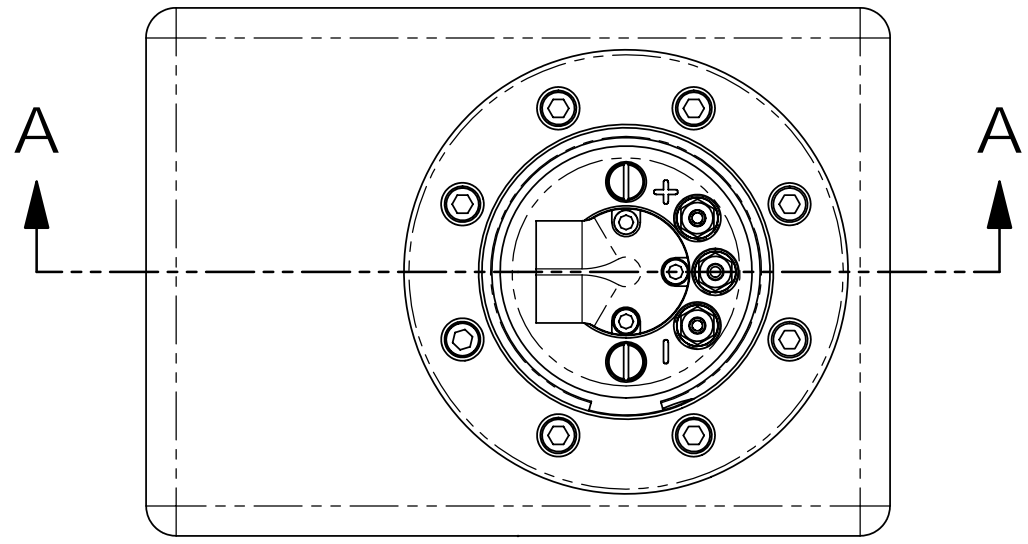

SCALE: 1/2

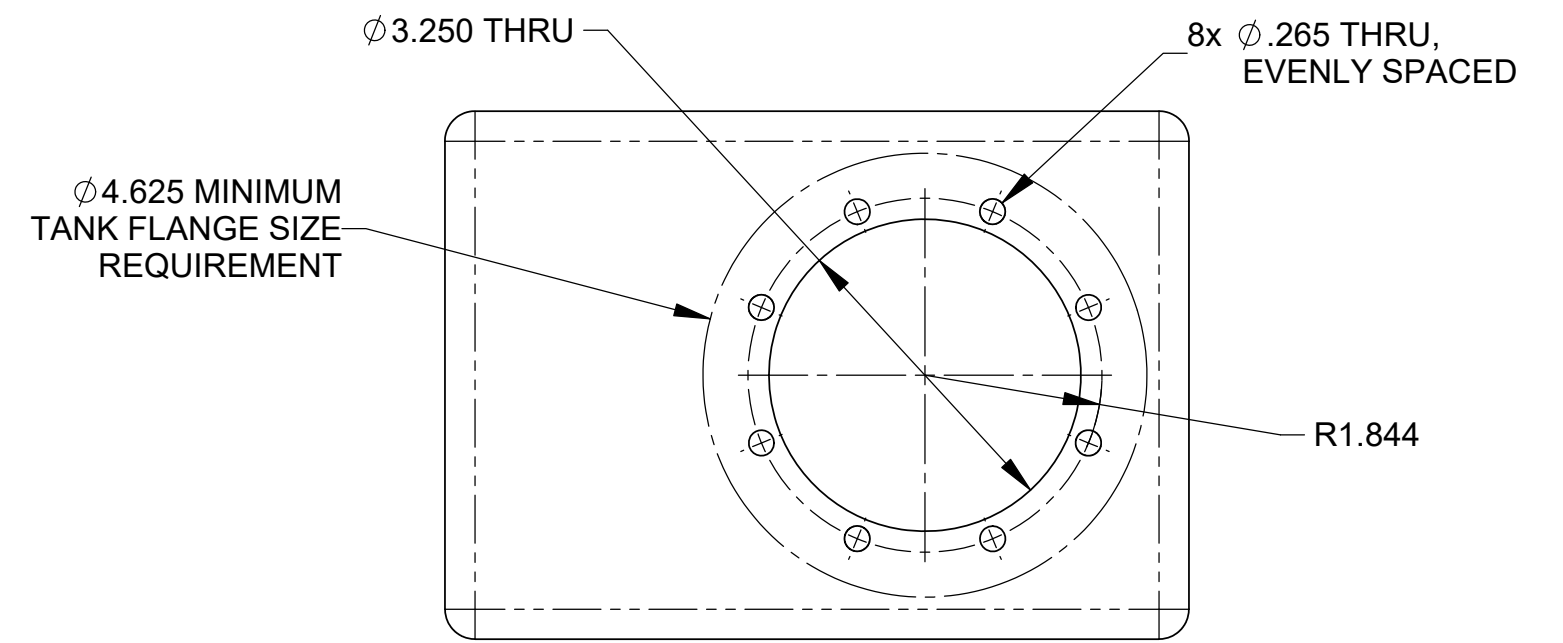

TANK FABRICATION REQUIREMENT
SHOWN ABOVE
SCALE: 1/2

FUELAB POWER MODULE
SHOWN INSTALLED.
(SOLD SEPARATELY)

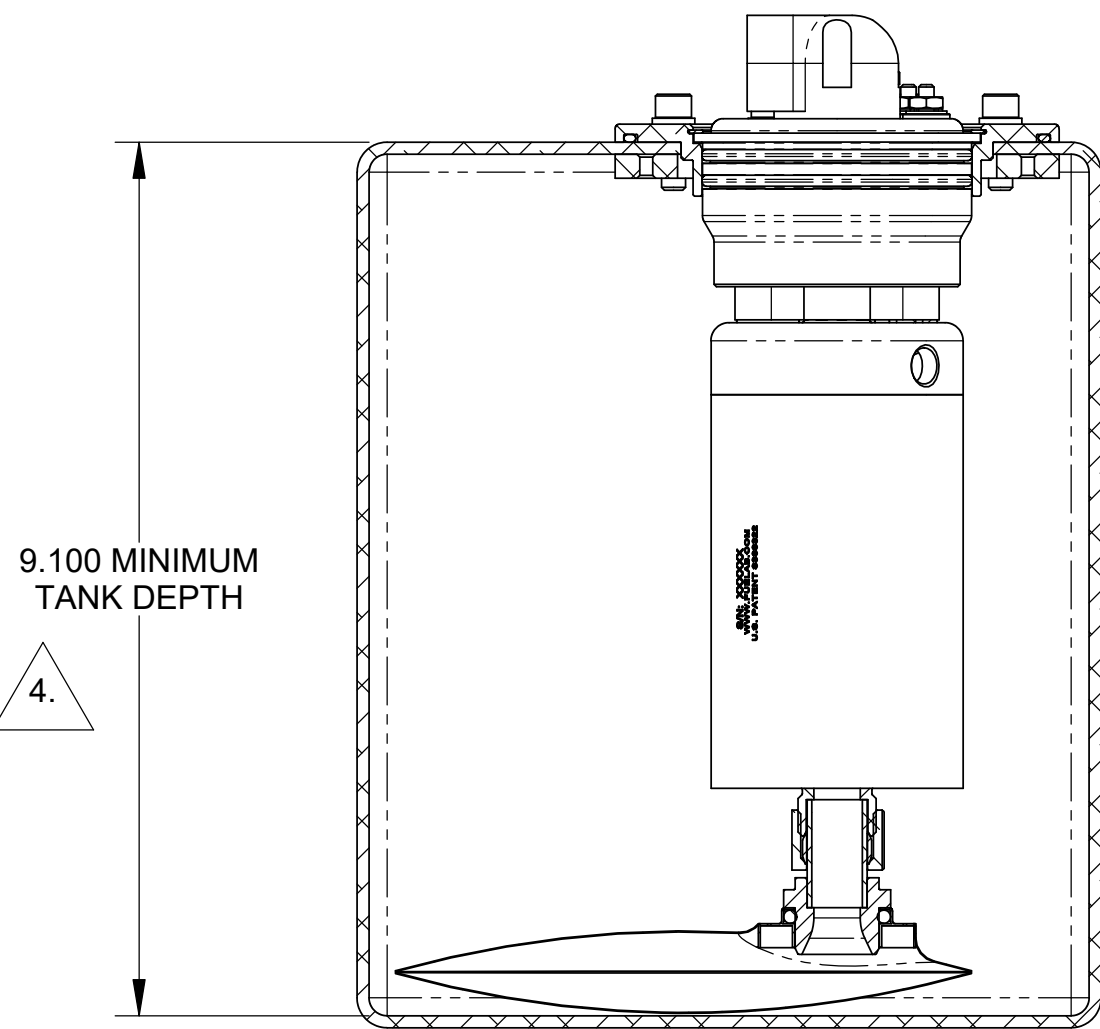

SECTION A-A
MINIMUM INSTALLATION HEIGHT
WITH MODELS 90902, 91901 AND 92902
SHOWN ABOVE
SCALE: 1/2

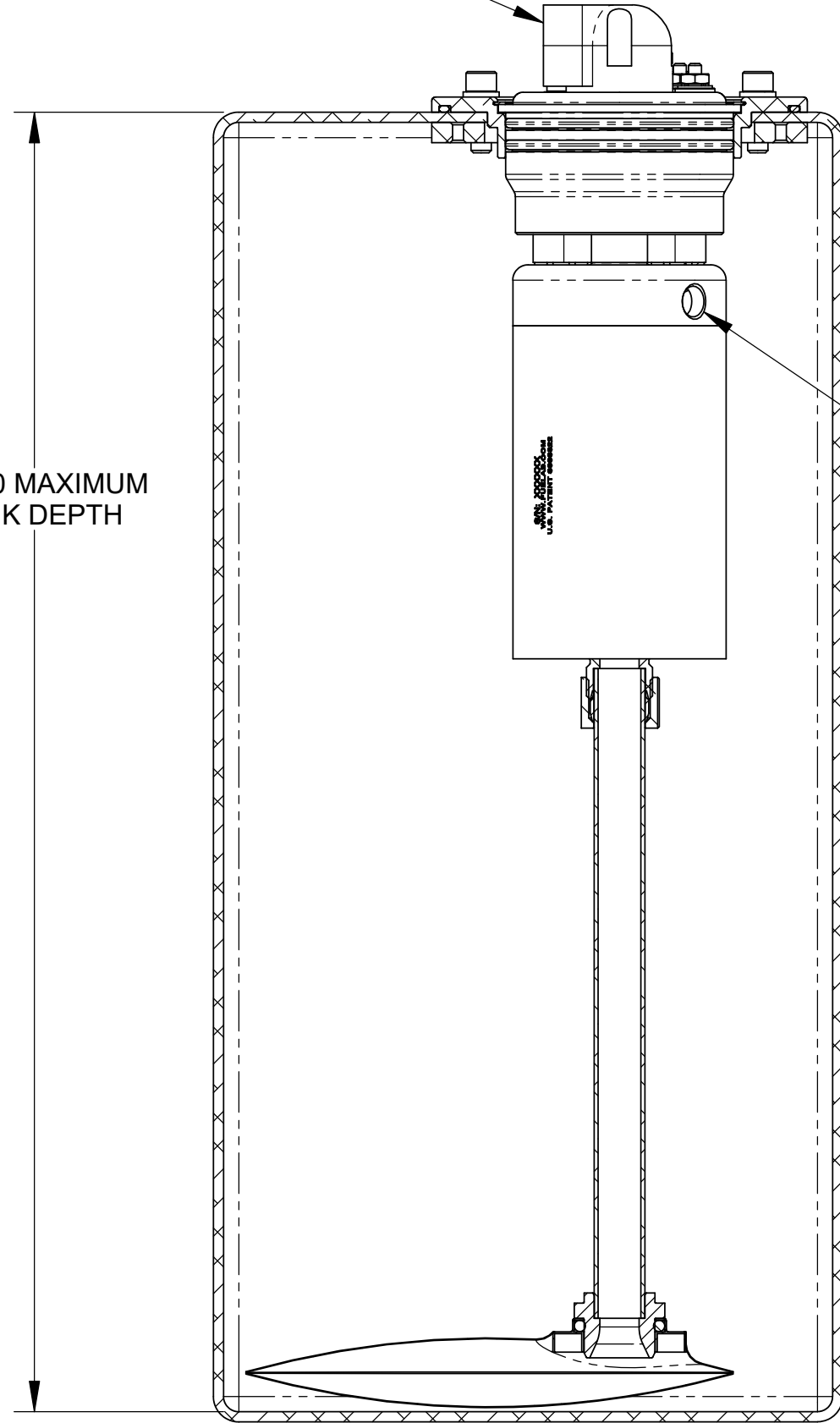

SECTION A-A
MAXIMUM INSTALLATION HEIGHT
WITH MODELS 90902, 91901 AND 92902
SHOWN ABOVE
SCALE: 1/2

2X OUTLET PORT FOR OPTIONAL
EXTERNAL EDUCTOR (JET) PUMP.

UNLESS OTHERWISE SPECIFIED:		COLLINSVILLE, ILLINOIS	
INTERPRET DWG PER ANSI Y14.5 DIMENSIONS ARE IN INCHES TOLERANCES: FRACTIONAL: ±1/64" ANGULAR: ±1/2° DECIMALS: X±1 .XX±0.03 .XXX±0.010 SURFACE FINISH: 128 ✓ OR BETTER BREAK ALL SHARP EDGES .010 MAX REMOVE ALL BURRS		TITLE: INSTALLATION KIT, MODEL 20901	
THIRD ANGLE PROJECTION 	SIZE C	DWG. NO. 149020100	REV A
DO NOT SCALE DRAWING	SCALE: 1/1	WEIGHT:	SHEET: 2 OF 2