

DETAIL A

STAGGARD HOLE PATTERN
ALLOWS MOUNTING TO EXISTING
CROSS MEMBERS

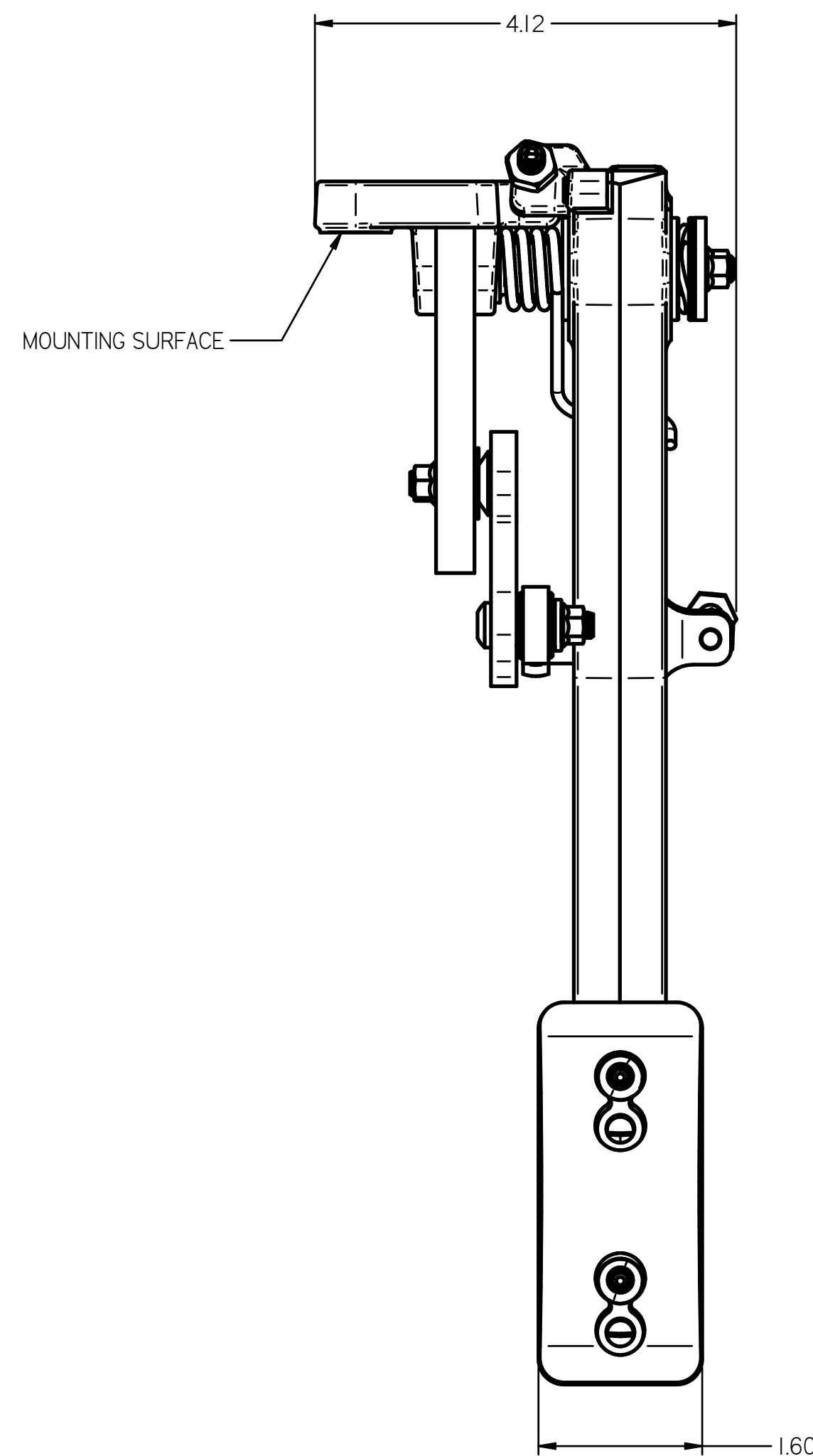
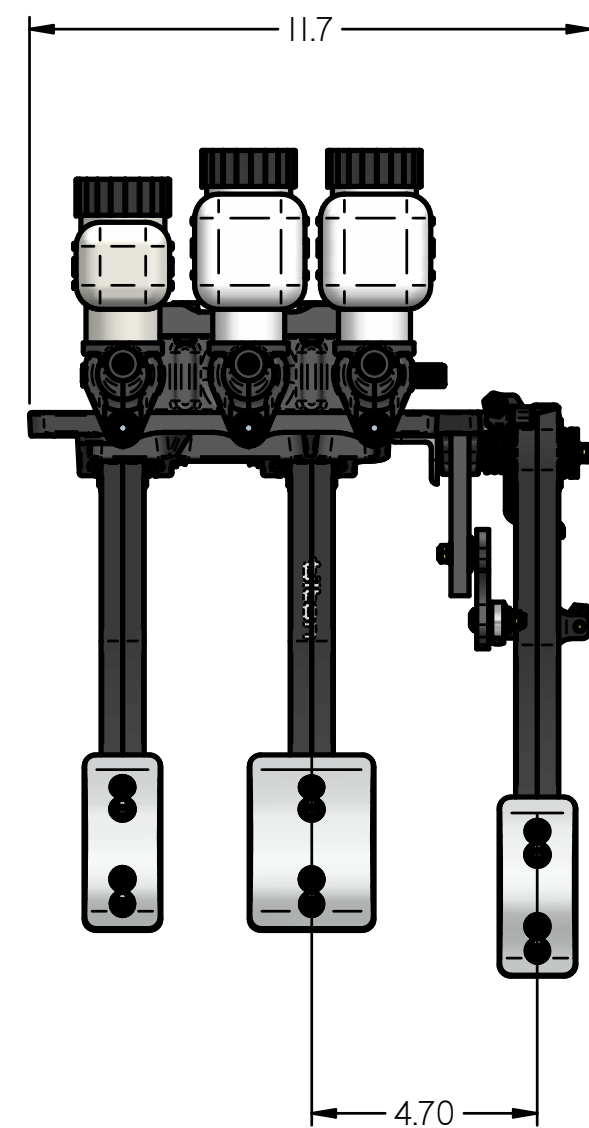

MOUNTING SURFACE

THROTTLE LINKAGE KIT
P/N: 72-791 (OPTIONAL)

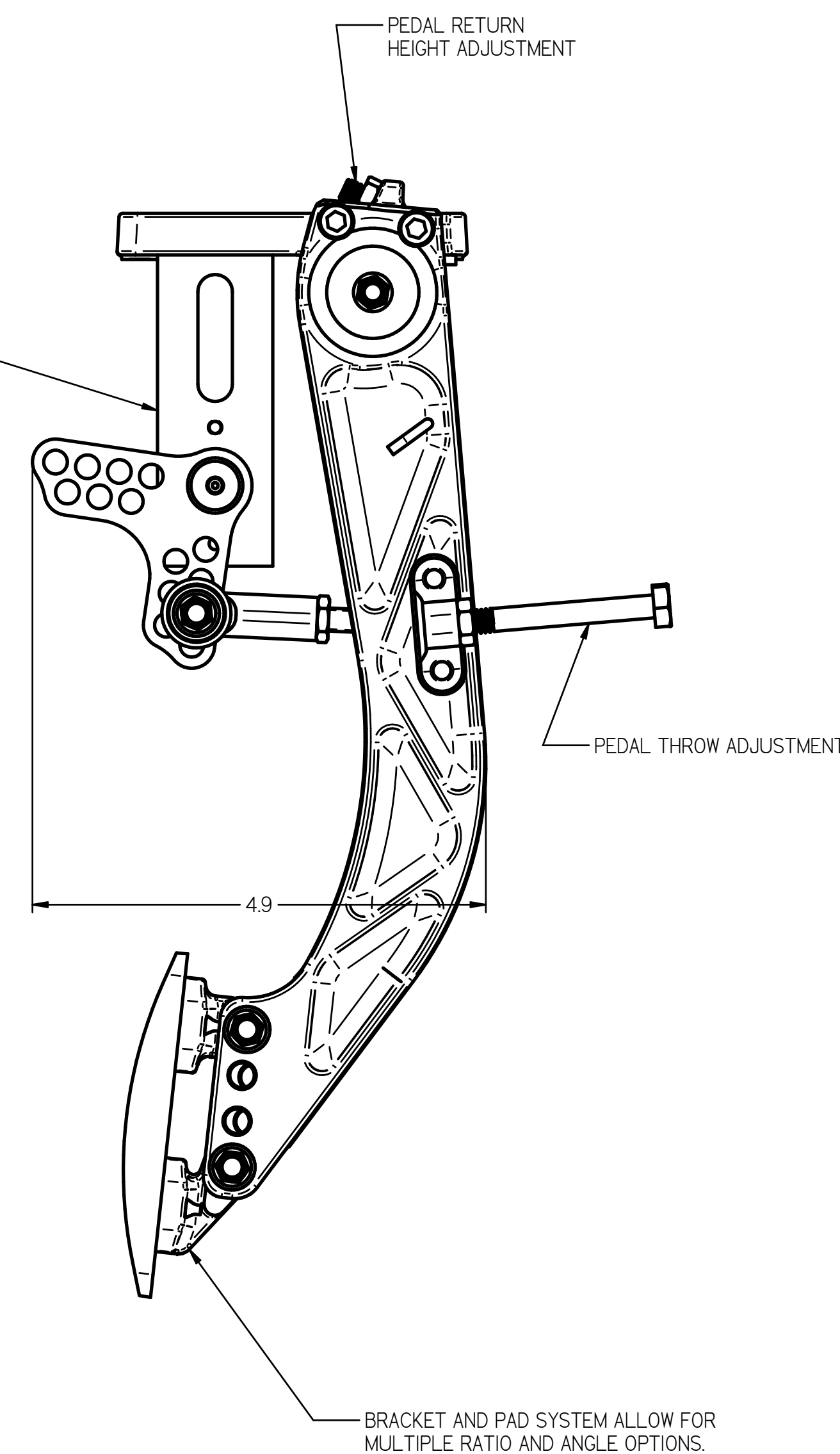

BRACKET AND PAD SYSTEM ALLOW FOR
MULTIPLE RATIO AND ANGLE OPTIONS.

SHOWN IN CONTEXT WITH 72-608
BRAKE AND CLUTCH PEDAL ASSEMBLY AND
75 SERIES MASTER CYLINDERS
(SOLD SEPARATELY)

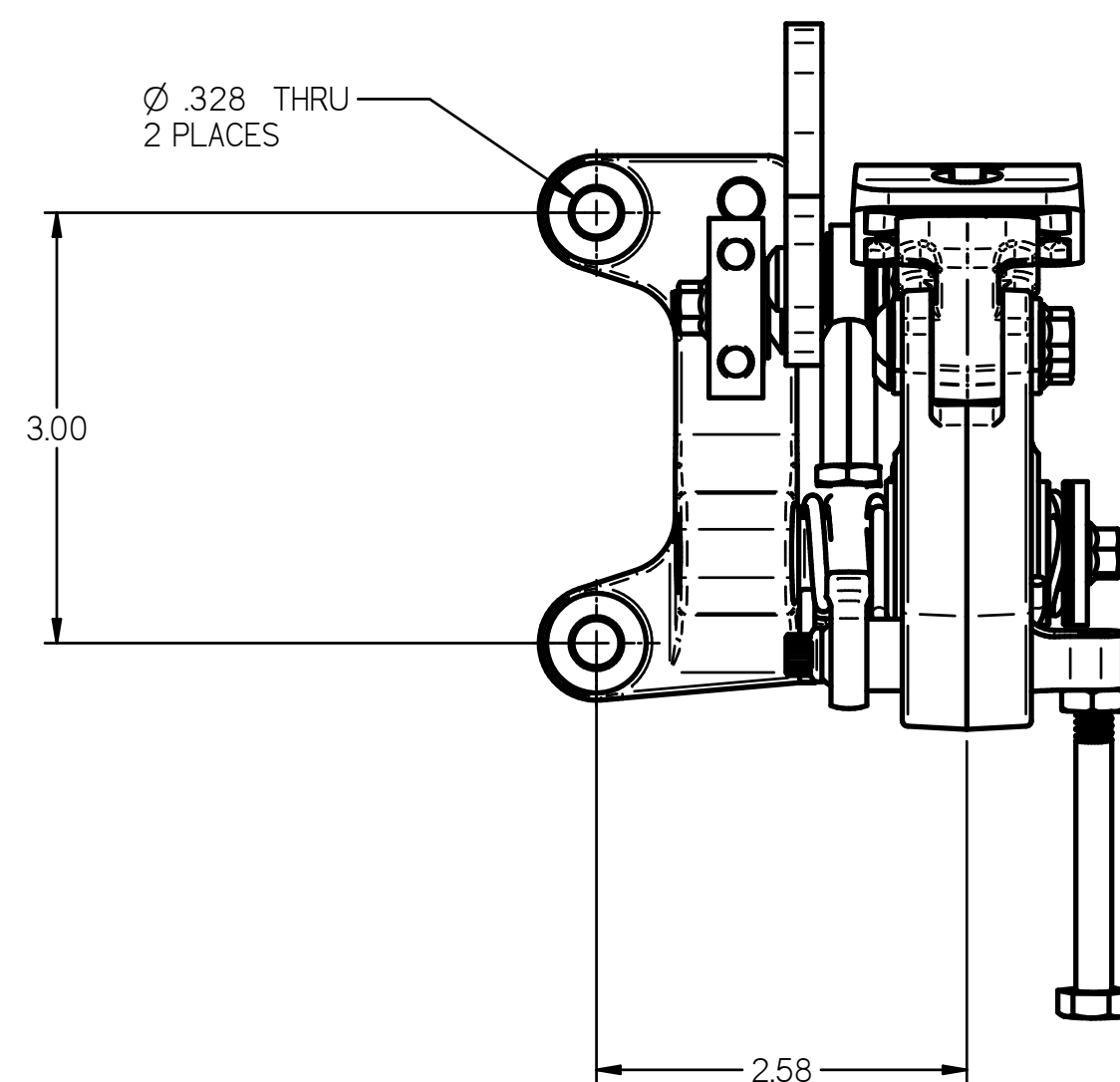
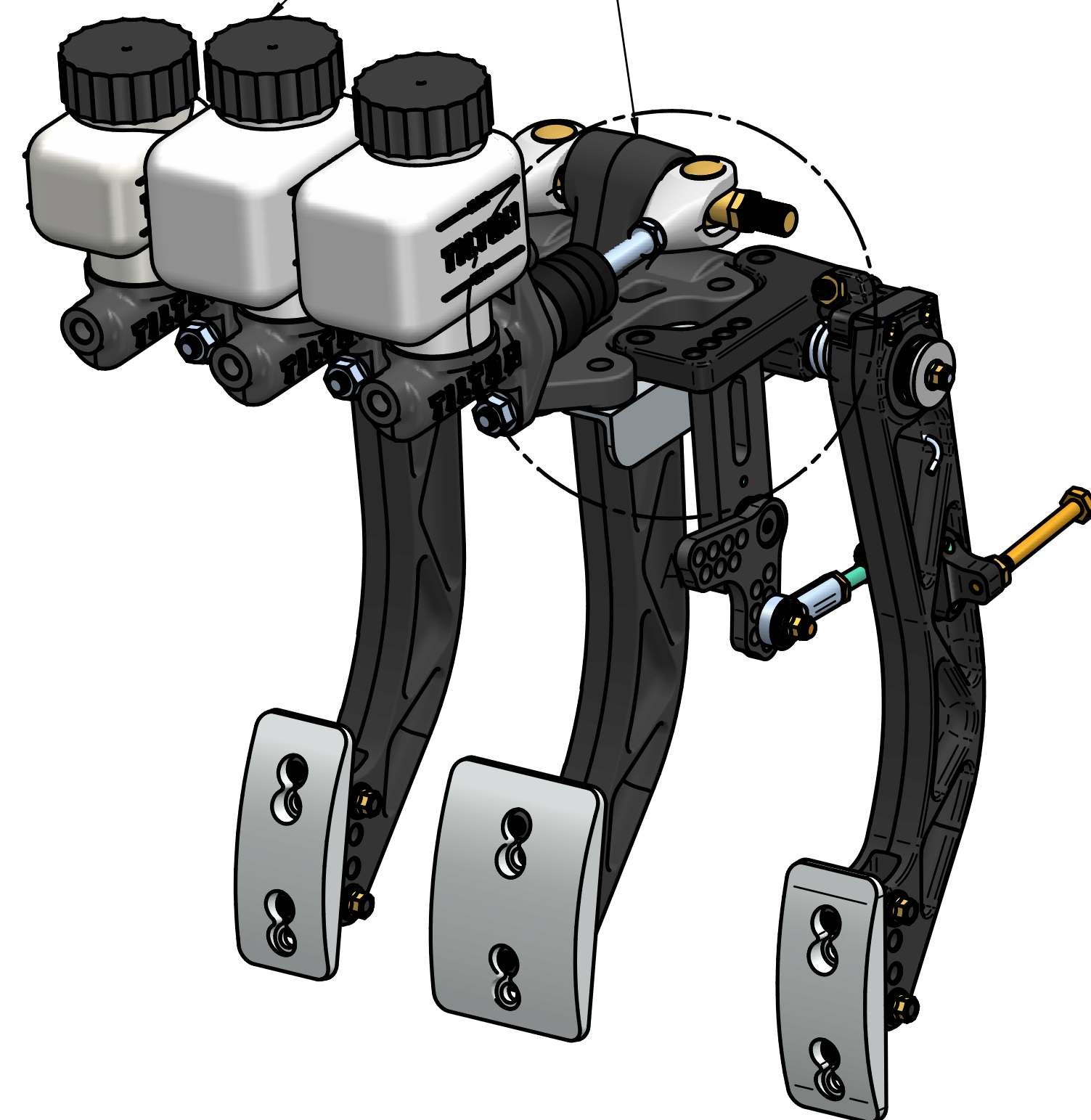

NOTES:

1. DIMENSIONS AND TOLERANCES PER ASME Y14.5 - 2009
2. UNLESS OTHERWISE SPECIFIED, ALL DIMENSIONS ARE IN INCHES.

TILTON ENGINEERING, INC.		(805) 688-2353 FAX (805) 688-2745	
25 EASY STREET P.O. BOX 1787		BUELLTON, CALIFORNIA 93427 USA	
TITLE:		INSTALLATION DRAWING	
		600 SERIES HANGING THROTTLE PEDAL ASSEMBLY	
DRN BY	WAHL	CHKD	LUND
P/N	72-615	DATE	03/04/2014
SCALE	1:2	DWG	5928
SHEET	1 OF 1	REV	B

"This document contains proprietary information of TILTON ENGINEERING, INC., and its receipt or possession does not convey the rights to reproduce, disclose its contents, or to manufacture, use or sell anything it may describe. Reproduction, disclosure, or use without specific written authorization of TILTON ENGINEERING, INC. is strictly forbidden."

TILTON ENGINEERING